

RADIAL PISTON PUMP

RKP-II

FOR LOW-FLAMMABILITY FLUIDS
HFA, HFB, HFC, HFD

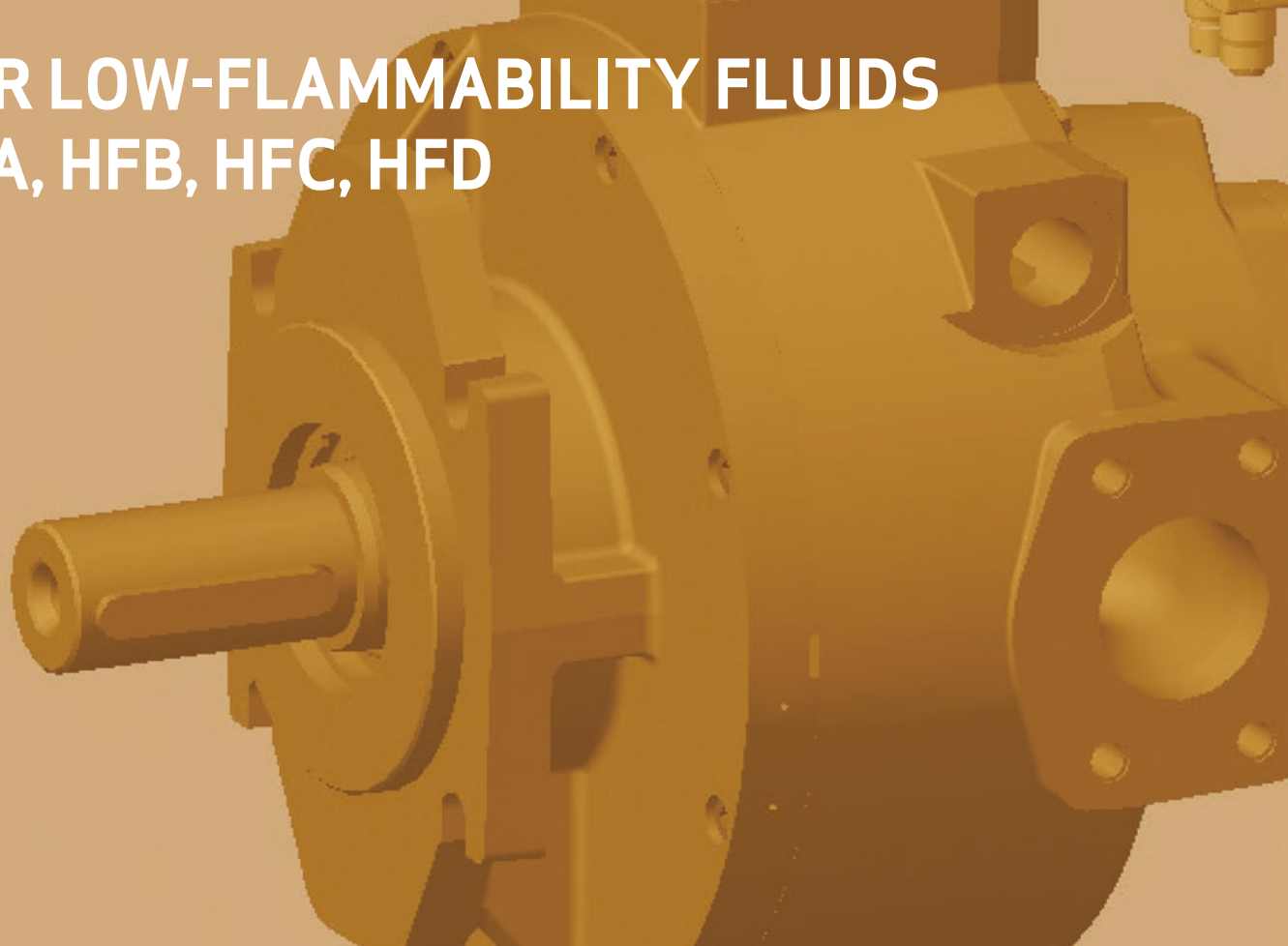

Rev. 3.1, May 2010

MOOG RKP PUMPS OFFER LOW NOISE, UNSURPASSED
RELIABILITY, LONG LIFE, AND A WIDE VARIETY OF
CONTROL OPTIONS FOR DEMANDING APPLICATIONS

RADIAL PISTON PUMPS RKP-II FOR LOW-FLAMMABILITY FLUIDS

CUTAWAY VIEW

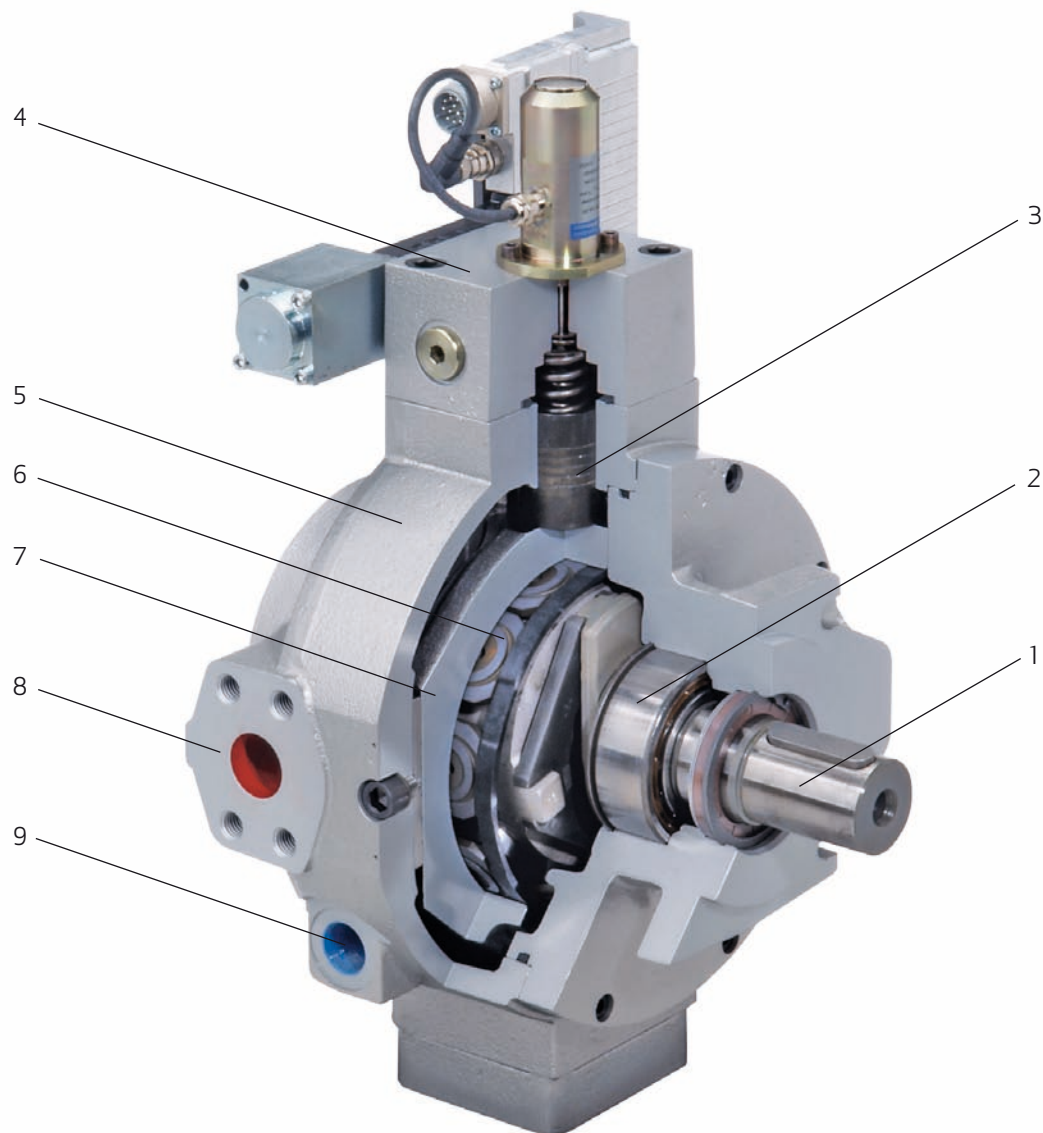

- 1 Drive shaft
- 2 Roller bearing
- 3 Control piston
- 4 Compensator
- 5 Housing
- 6 Slipper pads
- 7 Sliding stroke ring
- 8 SAE connection
- 9 Drain port

RADIAL PISTON PUMPS RKP-II FOR LOW-FLAMMABILITY FLUIDS

TABLE OF CONTENTS

TABLE OF CONTENTS

Cutaway view	2
Introduction	4
New design	5
Classification of HF fluids	6
Installation guidelines	8
Technical data for use with HF fluids	10
Characteristics	13
Multiple pumps	14
Compensator options	19
Type code HFA/HFB	20
Type code HFC	22
Type code HFD	24
Technical information	26
Appendix A - Compensator options	27
Appendix B - Housings, Flanges, Compensators	34
Moog Global Support™	59

IMPORTANT NOTE

This catalog is intended for users with some technical knowledge. To ensure that all necessary characteristics for function and safety are covered, the user must check the suitability of the products described herein. The products are subject to change without notice. In case of doubt, please contact Moog.

Moog is a registered trademark of Moog Inc. and its subsidiaries. Unless expressly indicated, all trademarks indicated herein are the property of Moog Inc. and its subsidiaries. For the full disclaimer, refer to: www.moog.com/literature/disclaimers.

© Moog Inc. 2010. All rights reserved. All changes are reserved.

For the most up-to-date information please visit our website at www.moog.com/industrial

All dimensions in mm

RADIAL PISTON PUMPS RKP-II FOR LOW-FLAMMABILITY FLUIDS

INTRODUCTION

GENERAL INFORMATION

Outstanding motion control solutions

For over 50 years, we have been a leader in motion control technology, specializing in the manufacture and application of high-performance products. Today, we incorporate the latest motion control technology into our products and offer innovative ideas that can help our customers achieve new levels of machine performance.

Proven pump technology

The Radial Piston Pump product line (also known as RKP), is a range of high-performance variable displacement pumps intended for use in industrial applications. Based on a proven concept, the RKP's robust and contamination-resistant design results in long life and a high degree of reliability.

Its rapid response time and high volumetric efficiency have led to it being the first choice for many machines with demanding flow and pressure control needs.

We produce a wide range of radial piston pumps of different sizes, single and multiple arrangements, with various forms of control (mechanical, hydro-mechanical, electro-hydraulic, digital and analog) in order to provide maximum flexibility to machine builders.

Applications

Thanks to the flexible, high-performance design, the new RKP-II is the ideal solution for all types of industrial applications. The RKP is already used in machines for injection molding, die casting, forming equipment such as presses and rolls, as well as in general hydraulic applications. In the field of plastic and metal processing, the RKP is used on equipment to produce plastic and metal parts, for the packaging and automotive industries. The RKP is also used in test equipment, construction, rubber processing, and the mining industry.

The new RKP-II is particularly well suited to applications where power, low noise and robust design, in combination with precision and speed are needed.

Low-noise and rugged design

With a number of innovative design features we have been able to reduce both the primary and the secondary noise level from the RKP-II. For pump sizes 63 cm³/rev (3.84 cu.in/rev) and 80 cm³/rev (4.88 cu.in/rev) the number of working pistons has also been increased from 7 to 9. This has made it possible to reduce the diameter of the working pistons, resulting in reduced dynamic variable forces acting on the housing and reduced flow and pressure ripple on the high-pressure and intake sides. Moog RKP-II helps machine manufacturers comply with EU directive "2003/10/EC" on noise emissions.

RADIAL PISTON PUMPS RKP-II FOR LOW-FLAMMABILITY FLUIDS

NEW DESIGN

NEW DESIGN

The new generation of RKP pumps, the RKP-II, benefits from reduced noise levels. They are now fitted with a sliding stroke ring. The suction port has been significantly increased in size, allowing a wide suction line to be directly connected. The control ports on the compensators are designed as G 1/4".

RKP-II stands for reliability, low noise, and durability. This is underlined by its extended warranty. Under the conditions described on Page 6, warranty for mineral oil is covered for 10,000 operating hours or 24 months. The existing modular system enables the user to choose a pump or pump combination individually tailored to the respective application.

Further advantages of the Moog radial piston pump RKP-II are:

- Fast response
- Compact modular design
- Good suction characteristics
- Low pressure ripple

The following RKP-II features are available:

- Medium-pressure series (280 bar (4,000 psi)) and high-pressure series (350 bar (5,000 psi)) for mineral oil
- Large selection of compensators including mechanical, hydraulic and electro-hydraulic (analog or digital with CAN bus)
- Mechanical flow limitation
- Multiple pumps by tandem mounting
- Various drive flanges
- Suitable for most hydraulic oils such as mineral oil, transmission oil, biodegradable oil
- Suitable for special fluids such as oil-in-water emulsions, (HFA), water-glycol (HFC), synthetic esters (HFD), and polyhydric alcohol

Mode of operation

The shaft (1) transfers the drive torque to the star-shaped cylinder block (3), free of any axial forces, via a crossdisc coupling (2). The cylinder block is hydrostatically supported on the control journal (4). The radial pistons (5) in the cylinder block run against the stroke ring (7) through hydrostatically balanced slipper pads (6). The pistons and slipper pads are joined by ball and socket joints and locking rings. The slipper pads are guided in the stroke ring by two retaining rings (8) and, when running, are held against the stroke ring by centrifugal force and oil pressure. As the cylinder block rotates, the pistons reciprocate due to the eccentric positioning of the stroke ring, the piston stroke being twice the eccentricity. The eccentricity is altered by two opposing control pistons (9, 10) in the pump housing. The oil flow to and from the pump passes through the pump ports and into and out of the pistons through the porting in the control journal. This is controlled by means of intake and pressure slits in the control journal. A compensator (11) monitors the system pressure and the stroke ring position (delivery). The hydraulic forces are not supported on the roller bearing. The bearing is thus free from load to a large extent.

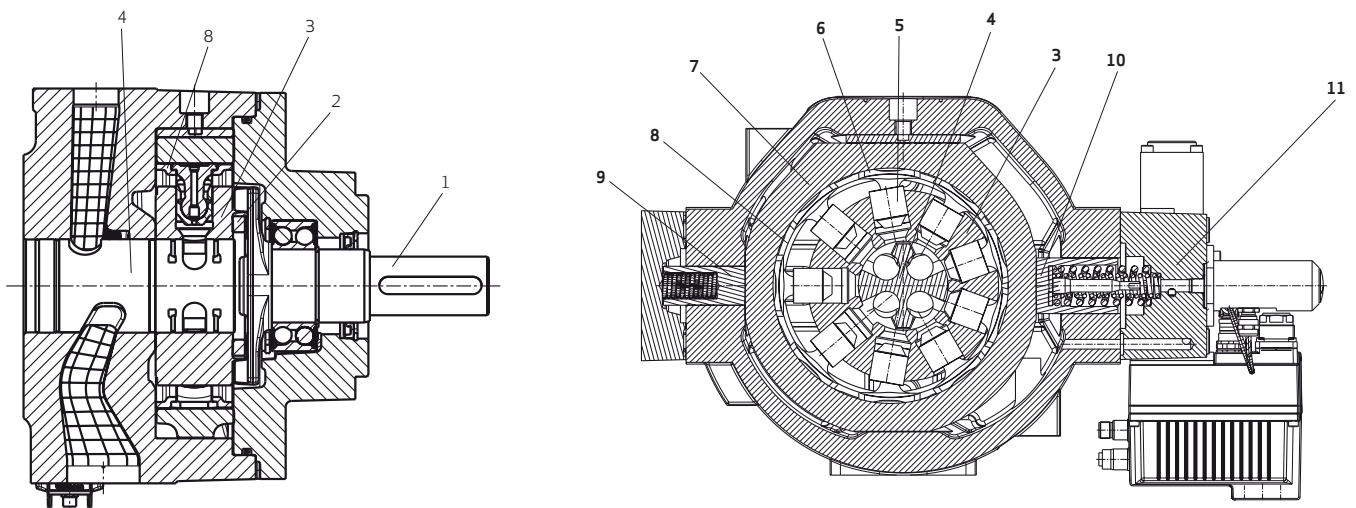

RADIAL PISTON PUMPS RKP-II FOR LOW-FLAMMABILITY FLUIDS

CLASSIFICATION OF HF FLUIDS

Classification of low-flammability fluids

Minimum technical requirements of low-flammability hydraulic fluids as per VDMA 24317

Class	HFA ¹⁾	HFB	HFC	HFD ²⁾
Composition	Oil-in-water emulsion approximately 95 % water	Water-in-oil emulsion approximately 40 % water	Aqueous polymer solutions (water-glycols)	Water-free, synthetic fluids Fatty acid ester (HFD-U) Phosphate ester (HFD-R)
Spontaneous ignition temperature °C (°F)	Possible	After evaporation of water below 1,000 °C (1,832 °F)	After evaporation of water below 1,000 °C (1,832 °F)	> 530 °C (> 986 °F)
Environmental protection, biodegradability	Good (synthetic)	Not possible	Not possible	Not possible
Lubricity	Satisfactory	Medium to good	Good	Excellent
Possible operating temperature	+5 °C to +50 °C (+41 °F to +122 °F)	+5 °C to +50 °C (+41 °F to +122 °F)	-10 °C to +55 °C (+14 °F to +131 °F)	0 °C to +80 °C (+32 °F to +176 °F)
Corrosion protection	Satisfactory	Good	Good	Satisfactory
Gasket material	HNBR	HNBR	HNBR	FPM, e.g. Viton
Seal compatibility	Good	Good	Excellent	Medium
Water content	80 % to 95 %	approximately 40 %	35 % to 55 %	< 0.1 %

¹⁾ Subdivision of HFA fluids VDMA 24317, see Page 6

²⁾ Subdivision of HFD fluids VDMA 24317, see Page 7

HFA fluids

These are characterized by a particularly high water content of approximately 95 %. The viscosity of these media is naturally very low, placing great demands on the pumps and other components.

These fluids can be broken down into the following different subcategories:

HFAE mineral oil or macroemulsions

Made up of approximately 95 % water and approximately 5 % mineral oil (frequent mixture ratio), emulsifying agents and additives. This 2-phase system is known as emulsion. In this milky-white emulsion oil particles (40 µm to 250 µm (0.0016 in to 0.01 in)) are dispersed in the water.

HFAE microemulsion

In microemulsion the oil particles (2 µm to 25 µm (0.00008 in to 0.001 in)) are smaller than in macroemulsion.

The transparent microemulsion contains highly effective additives which improve the lubrication of aqueous fluids, thus resulting in high wear protection.

HFAS synthetic fluids

These solutions are mineral-oil-free. They are characterized by a high resistance to microbes and are extremely stable. There is no possibility of phase separation, as can occur in emulsions. Dyes are sometimes added to the normally clear fluid to make it more visible.

Storage life

HFA fluids are stable in the temperature range $T = 0\text{ °C}$ to approximately $+50\text{ °C}$ ($+32\text{ °F}$ to approximately $+122\text{ °F}$). Below 0 °C (32 °F) the fluid freezes; alternate freezing and thawing will cause phase separation of the emulsion.

Synthetic fluids, however, are not subject to phase separation. These fluids evaporate more quickly at temperatures in excess of 50 °C (122 °F).

RADIAL PISTON PUMPS RKP-II FOR LOW-FLAMMABILITY FLUIDS

CLASSIFICATION OF HF FLUIDS

HFB fluids

These are water-in-oil emulsions with a water content of approximately 40 %. They are ready to use on delivery and have a nominal viscosity similar to that of hydraulic oils. They are used relatively rarely, because they do not always comply with fire test regulations. They are of practical importance particularly in British coal mining operations.

HFC fluids

These fluids are the closest to mineral-oil-based hydraulic oils in terms of their physical and chemical properties, and comply with most fire test regulations. Their importance in the market is relatively high. Many hydraulic components can be easily converted from mineral oil to HFC fluids.

HFC fluids are aqueous polymer solutions. They are ready to use on delivery and, depending on the viscosity requirements of the drive, can be used at hydraulic fluid temperatures of -10°C to $+55^{\circ}\text{C}$ ($+14^{\circ}\text{F}$ to $+131^{\circ}\text{F}$).

In order to keep the loss of water content due to evaporation to a minimum, the hydraulic fluid temperature should if possible not exceed 50°C . The water content must be monitored during operation and, in the event of a marked deviation, kept at the desired level by adding demineralized water.

HFD fluids

These synthetic fluids are water-free and are usually based on phosphoric esters (HFD-R) and synthetic or natural fatty acid esters (HFD-U). They are characterized by their resistance to aging and good wear protection, and can be used in wide temperature ranges. Occasionally they require special seals and can be aggressive to various metal compounds, paints and lacquers (refer to the manufacturer's instructions). RKP-II pumps for HFD fluids are supplied with FPM seals as standard.

Flushing the bearing in the case of HFC fluids

Flushing the bearing is mandatory for size 32 to 140 pumps. Flushing is generally performed automatically via a corresponding hole in the bearing cap, and in some case via an external flushing port on the bearing cap. The cleanliness of the flushing fluid is governed by the same requirements as those for the pump.

Disposal

These fluids must be disposed of in accordance with the manufacturer's instructions (see DIN safety data sheet for the fluid) and/or statutory provisions.

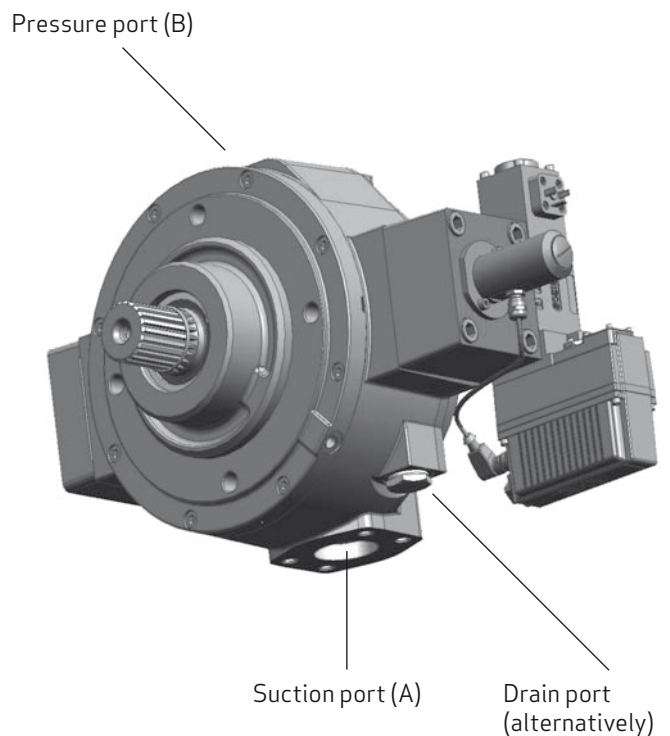
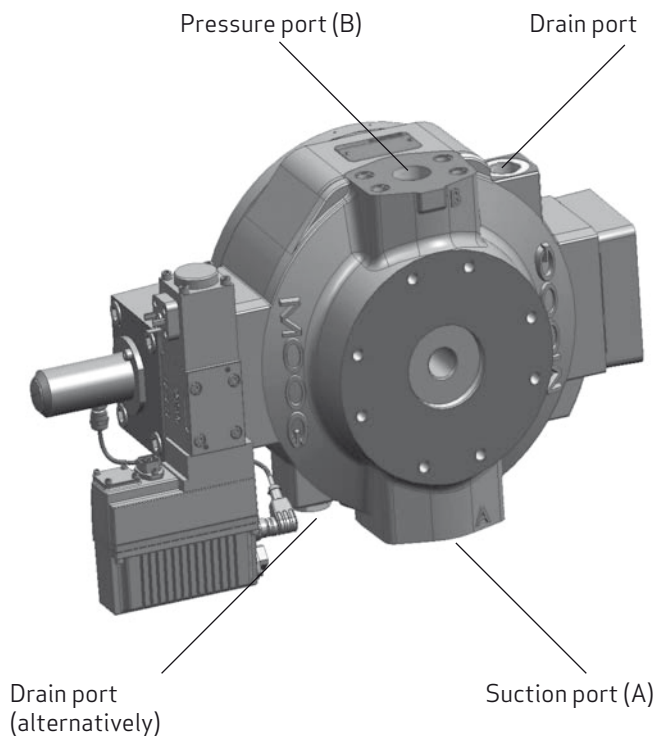

RADIAL PISTON PUMPS RKP-II FOR LOW-FLAMMABILITY FLUIDS

INSTALLATION GUIDELINES

Installation guidelines for HFA pumps

- 1 Pump layout exclusively with a horizontal drive shaft.
- 2 The shafts of the pump and electric motor must be perfectly flush. Use a properly centered pump carrier with a flexible coupling.
- 3 Pump layout below the minimum fluid level, i.e. directly next to or under the tank. Installation in the tank is not permitted.
- 4 Suction line should have short and large nominal diameters where possible, avoid bends; $V_{max} \leq 1.5 \text{ m/s}$ (4 ft 11 in/s)
- 5 Drain line: use an upper drain port; large nominal diameters where possible; end of line below the min. fluid level; use flexible material.
- 6 Lay high-pressure lines and other lines so that they are silently mounted.
- 7 Tank: corrosion-resistant, particularly above the fluid level (condensation water).
Take care on coats of paint - HFA is occasionally alkaline.
Electric fill level monitoring.
- 8 Filtering:
 - 8.1 Tank ventilation $3 \mu\text{m}$ ($> 0.00012 \text{ in}$), corrosion-resistant
 - 8.2 Return line $\beta_{10} = 75$
 - 8.3 High-pressure line $\beta_{10} = 75$
- 9 Inspection hole in the pump carrier vertically at the bottom so as to detect possible leakage at the shaft seal. The unplugged inspection hole must always be at the bottom. If necessary, the mounting flange must be rotated.

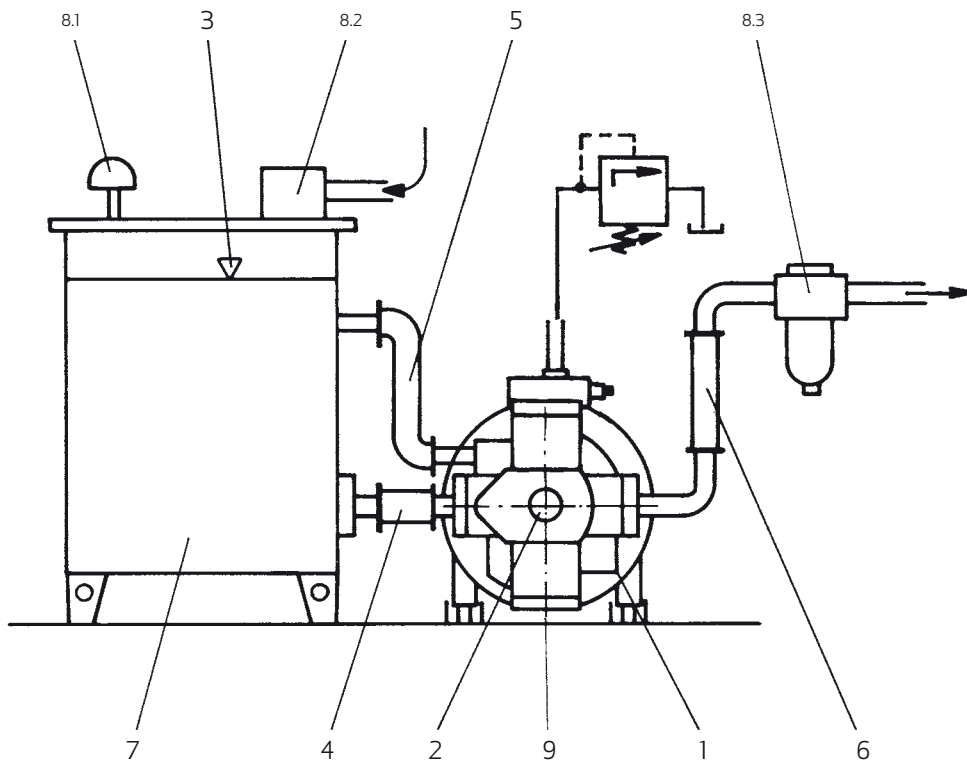

RADIAL PISTON PUMPS RKP-II FOR LOW-FLAMMABILITY FLUIDS

INSTALLATION GUIDELINES

Preparing and maintaining the HFA fluid

The HFA fluid must be prepared and maintained in accordance with the manufacturer's instructions. The hydraulic fluid temperature should be kept as low as possible within the range of + 5 °C to + 40 °C (+41 °F to +104 °F). A maximum temperature of 50 °C (122 °F) is permitted for radial piston pumps. At high hydraulic fluid temperatures there is an increased risk of cavitation (gap to the vapor phase gets smaller) and there is an increased build-up of bacteria. The tank should therefore be fitted with a temperature monitor.

Starting up an HFA system

Before it is started up for the first time, the pump must be filled with HFA fluid via the drain port. The first revolutions must be completed at a pressure $p \leq 20$ bar (≤ 290 psi), where the temperature difference between the tank and the pump must not exceed 25 °C (> 77 °F). When the suction and drain lines are free of air bubbles, the pump may be subjected to load after a few minutes.

The unit must remain filled with fluid through periods of extended shutdown. Before being returned to service, the valves and pumps must be checked to ensure that they move freely.

If the pump can be rotated slightly by hand at the electric motor (fan impeller), it can be returned to service. A pump must always be treated with preservative agent after being removed from a system. The housing, inlet port and pressure port are drained. The housing is then filled with hydraulic oil, in the course of which the drive shaft is rotated until oil emerges from the pressure and inlet ports.

The pump is now sealed at the suction, pressure and drain ports.

For further details, refer to the RKP-II user information.

RADIAL PISTON PUMPS RKP-II FOR LOW-FLAMMABILITY FLUIDS

TECHNICAL DATA FOR USE WITH HFA/HFB FLUIDS

Parameters			
Displacement [cm³/rev] ([cu.in/rev])	19 (1.16)	32 (1.95)	63/80 (3.84/4.88)
Type of construction	Pump for open circuit with various control devices		
Type of mounting	Drive flange A7: Straight key according to ISO 2491, 4-hole ISO flange according to ISO 3019/2 (metric)		
Mounting position	Horizontal (drive shaft horizontal)		
Weight [kg] ([lb])	22 (48.5)	33 (72.8)	71 (156.5)
Mass moment of inertia [kg cm ²] ([lb sq.in])	17.7 (6.05)	33 (11.28)	186.3 (63.7)
Line connections acc. to ISO 6162: Pressure port	SAE 3/4" 3,000 psi	SAE 1" 3,000 psi	SAE 1 1/4" 3,000 psi
Suction port	SAE 3/4" 3,000 psi	SAE 1 1/2" 3,000 psi	SAE 2" 3,000 psi
Recommended pipe outside diameter for drain lines (lightweight version) [mm] ([in])	15 (0.59)	18 (0.71)	22 (0.87)
Drain port	The drain line is to be routed so that the housing is always full of the hydraulic fluid. The pressure at the Drain port must not exceed 2 bar (29.0 psi) absolute (1 bar (14.5 psi) gage pressure). End of line below the fluid level. No filter or non-return valve in the drain line.		
Type of drive	Direct drive with flexible coupling (please inquire from your Moog contact for other types)		
Ambient temperature range	0 °C to +60 °C (+32 °F to +140 °F)		
Maximum speed at inlet pressure 0.8 bar (11.6 psi) absolut [rpm] 1.0 bar (14.5 psi) absolut [rpm]	1,500 1,800	1,500 1,800	1,500 1,800
Min. inlet pressure suction port	0.8 bar (11.6 psi) absolute		
Maximum housing pressure	2 bar (29.0 psi) (1 bar (14.5 psi) gage pressure)		
Continuous pressure [bar] ([psi]) Maximum pressure ¹⁾ [bar] ([psi]) Pressure peak [bar] ([psi])	120 (1,740) 160 (2,320) 210 (3,000)	120 (1,740) 160 (2,320) 210 (3,000)	120 (1,740) 160 (2,320) 210 (3,000)
Hydraulic fluid	HFA, oil-in-water emulsions		
Hydraulic fluid temperature range	+5 °C to +50 °C (+41 °F to +122 °F)		
Viscosity	approximately 1 mm ² /s		
Filtering	NAS 1638, class 7; ISO 4406, class 18/16/13; obtained with filter fineness $\beta_{10} = 75$ ²⁾		

¹⁾ Maximum pressure according to DIN 24 312

²⁾ Dirt particles retention rate > 10 µm (> 0.0004 in) is 1: 75, i.e. 98.67 %
1,000 psi = 70 bar

RADIAL PISTON PUMPS RKP-II FOR LOW-FLAMMABILITY FLUIDS

TECHNICAL DATA FOR USE WITH HFC FLUIDS

Parameters							
Displacement [cm³/rev] ([cu.in/rev])	19 (1.16)	32 (1.95)	45 (2.75)	63 (3.84)	80 (4.88)	100 (6.10)	140 (8.54)
Type of construction	Pump for open circuit with various control devices						
Type of mounting	End mounting, centering and hole-circle dia. according to ISO 3019/2 (metric) Mounting flange according to ISO 3019/1 (imperial dimensions) Mounting flange according to ISO 3019/2 (metric)						
Mounting position	Optional						
Weight [kg] ([lb])	22 (48.5)	33 (72.8)	33 (72.8)	71 (156.5)	71 (156.5)	71 (156.5)	105 (231.5)
Mass moment of inertia [kg cm ²] ([lb sq.in])	17.7 (6.05)	61.0 (20.84)	61.0 (20.84)	186.3 (63.7)	186.3 (63.7)	186.3 (63.7)	380.0 (130)
Line connections acc. to ISO 6162: Pressure port	SAE 3/4" 3,000 psi	SAE 1" 3,000 psi	SAE 1" 3,000 psi	SAE 1 1/4" 3,000 psi	SAE 1 1/4" 3,000 psi	SAE 1 1/4" 6,000 psi	SAE 1 1/2" 6,000 psi
Suction port	SAE 3/4" 3,000 psi	SAE 1 1/2" 3,000 psi	SAE 1 1/2" 3,000 psi	SAE 2" 3,000 psi	SAE 2" 3,000 psi	SAE 2" 3,000 psi	SAE 2 1/2" 3,000 psi
Recommended pipe outside diameter for drain lines (lightweight version) [mm] ([in])	15 (0.59)	18 (0.71)	18 (0.71)	22 (0.87)	22 (0.87)	22 (0.87)	22 (0.87)
Drain port	The drain line is to be routed so that the housing is always full of the hydraulic fluid. The pressure at the drain port must not exceed 2 bar (29.0 psi) absolute (1 bar (14.5 psi) gage pressure). End of line below the fluid level. No filter or non-return valve in the drain line.						
Recommended flushing quantity l/min (gpm)	-	4 to 5 (0.88 to 1.10)	4 to 5 (0.88 to 1.10)	6 to 7 (1.32 to 1.54)	5 to 7 (1.10 to 1.54)	5 to 7 (1.10 to 1.54)	7 to 10 (1.54 to 2.20)
Type of drive	Direct drive with flexible coupling (please inquire from your Moog contact for other types)						
Ambient temperature range	0 °C to +60 °C (+32 °F to +140 °F)						
Maximum speed at inlet pressure 0.8 bar (11.6 psi) abs. [rpm] 1.0 bar (14.5 psi) abs. [rpm]	1,800 1,800	1,800 1,800	1,800 1,800	1,800 1,800	1,500 1,800	1,500 1,800	1,500 1,800
Maximum speed for low-noise operation [rpm]	1,800	1,800	1,800	1,800	1,800	1,800	1,800
Min. inlet pressure suction port	0.8 bar (11.6 psi) absolute						
Maximum housing pressure	2 bar (29.0 psi) (1 bar (14.5 psi) gage pressure)						
Continuous pressure [bar] ([psi])	210 (3,000)	210 (3,000)	210 (3,000)	210 (3,000)	210 (3,000)	210 (3,000)	210 (3,000)
Maximum pressure ¹⁾ [bar] ([psi])	230 (3,340)	230 (3,340)	230 (3,340)	230 (3,340)	230 (3,340)	230 (3,340)	230 (3,340)
Pressure peak [bar] ([psi])	260 (3,770)	260 (3,770)	260 (3,770)	260 (3,770)	260 (3,770)	260 (3,770)	260 (3,770)
Hydraulic fluid	HFC, aqueous polymer solutions						
Hydraulic fluid temperature range	-10 °C to +55 °C (+14 °F to +131 °F)						
Viscosity	Allowable operational range 12 mm ² /s to 100 mm ² /s; recommended operational range 16 mm ² /s to 46 mm ² /s Hydraulic fluid according to viscosity class ISO VG 46 or VG 32 Maximum viscosity 500 mm ² /s during start-up with electric motor at 1,800 rpm						
Filtering	NAS 1638, class 9; ISO 4406, class 20/18/15; obtained with filter fineness $\beta_{20} = 75$ ²⁾ NAS 1638, class 7; ISO 4406, class 18/16/13; with electro-hydraulic control (RKP-D)						

¹⁾ Maximum pressure according to DIN 24 312

²⁾ Dirt particles retention rate > 20 µm is 1: 75, i.e. 98.67 %
1,000 psi = 70 bar

RADIAL PISTON PUMPS RKP-II FOR LOW-FLAMMABILITY FLUIDS

TECHNICAL DATA FOR USE WITH HFD FLUIDS

Parameters							
Displacement [cm³/rev] ([cu.in/rev])	19 (1.16)	32 (1.95)	45 (2.75)	63 (3.84)	80 (4.88)	100 (6.10)	140 (8.54)
Type of construction	Pump for open circuit with various control devices						
Type of mounting	End mounting, centering and hole-circle dia. according to ISO 3019/2 (metric) Mounting flange according to ISO 3019/1 (imperial dimensions) Mounting flange according to ISO 3019/2 (metric)						
Mounting position	Optional						
Weight [kg] ([lb])	22 (48.5)	33 (72.8)	33 (72.8)	71 (156.5)	71 (156.5)	71 (156.5)	105 (231.5)
Mass moment of inertia [kg cm ²] ([lb sq.in])	17.7 (6.05)	61.0 (20.84)	61.0 (20.84)	186.3 (63.7)	186.3 (63.7)	186.3 (63.7)	380.0 (130)
Line connections according to ISO 6162: Medium-pressure series 280 bar (4,000 psi) Pressure port							
Suction port	SAE 3/4" 3,000 psi	SAE 1" 3,000 psi	SAE 1" 3,000 psi	SAE 1 1/4" 3,000 psi	SAE 1 1/4" 3,000 psi	SAE 1 1/4" 6,000 psi	SAE 1 1/2" 6,000 psi
High-pressure series 350 bar (5,000 psi) Pressure port	SAE 3/4" 3,000 psi	SAE 1 1/2" 3,000 psi	SAE 1 1/2" 3,000 psi	SAE 2" 3,000 psi	SAE 2" 3,000 psi	SAE 2" 3,000 psi	SAE 2 1/2" 3,000 psi
Suction port	SAE 3/4" 6,000 psi SAE 3/4" 6,000 psi	SAE 1" 6,000 psi SAE 1 1/2" 3,000 psi		SAE 1 1/4" 6,000 psi SAE 2" 3,000 psi	SAE 1 1/4" 6,000 psi SAE 2" 3,000 psi		
Recommended pipe outside diameter for drain lines (lightweight version) [mm] ([in])	15 (0.59)	18 (0.71)	18 (0.71)	22 (0.87)	22 (0.87)	22 (0.87)	22 (0.87)
Drain port	The drain line is to be routed so that the housing is always full of the hydraulic fluid. The pressure at the drain port must not exceed 2 bar (29.0 psi) absolute (1 bar (14.5 psi) gage pressure). End of line below the fluid level. No filter or non-return valve in the drain line.						
Type of drive	Direct drive with flexible coupling (please inquire from your Moog contact for other types)						
Ambient temperature range	0 °C to +60 °C (+32 °F to +140 °F)						
Maximum speed at inlet pressure 0.8 bar abs. [rpm] 1.0 bar abs. [rpm]	2,700 2,900	2,500 2,900	1,800 2,100	2,100 2,300	1,500 1,800	1,500 1,800	1,500 1,800
Maximum speed for low-noise operation [rpm]	1,800	1,800	1,800	1,800	1,800	1,800	1,800
Min. inlet pressure suction port	0.8 bar (11.6 psi) absolute						
Maximum housing pressure	2 bar (29.0 psi) (1 bar (14.5 psi) gage pressure)						
Medium-pressure version Continuous pressure Max. pressure ¹⁾ [bar] ([psi]) Pressure peak	280 (4,000) 315 (4,570) 350 (5,000)	280 (4,000) 315 (4,570) 350 (5,000)	280 (4,000) 315 (4,570) 350 (5,000)	280 (4,000) 315 (4,570) 350 (5,000)	280 (4,000) 315 (4,570) 350 (5,000)	280 (4,000) 315 (4,570) 350 (5,000)	280 (4,000) 315 (4,570) 350 (5,000)
High-pressure version Continuous pressure Max. pressure ¹⁾ [bar] ([psi]) Pressure peak	350 (5,000) 385 (5,580) 420 (6,000)	350 (5,000) 385 (5,580) 420 (6,000)		350 (5,000) 385 (5,580) 420 (6,000)	350 (5,000) 385 (5,580) 420 (6,000)		
Hydraulic fluid	HFD-U (HFD-R after consultation)						
Hydraulic fluid temperature range	0 °C to +80 °C (+32 °F to +176 °F)						
Viscosity	Allowable operational range 12 mm ² /s to 100 mm ² /s; recommended operational range 16 mm ² /s to 46 mm ² /s. Hydraulic fluid according to viscosity class ISO VG 46 or VG 32 Maximum viscosity 500 mm ² /s during start-up with electric motor at 1,800 rpm						
Filtering	NAS 1638, class 9; ISO 4406, class 20/18/15; obtained with filter fineness $\beta_{20} = 75$ ²⁾ NAS 1638, class 7; ISO 4406, class 18/16/13; with electro-hydraulic control (RKP-D)						

¹⁾ Maximum pressure according to DIN 24 312

²⁾ Dirt particles retention rate > 20 µm (> 0.0008 in) is 1: 75,
i.e. 98.67 %

1,000 psi = 70 bar

RADIAL PISTON PUMPS RKP-II FOR LOW-FLAMMABILITY FLUIDS

PERFORMANCE CURVES

ADJUSTMENT RANGE

⚠ Caution

The direction of rotation cannot be changed!

Clockwise rotation

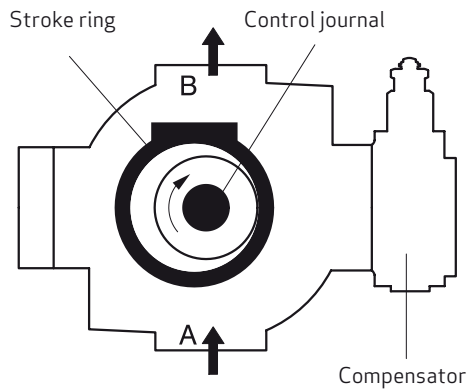

Counterclockwise rotation

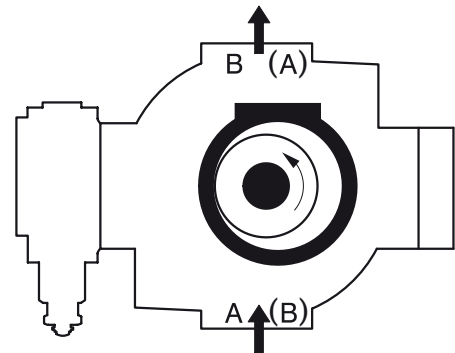

Note: Except for RKP 19

Counterclockwise rotation:

Suction port (B)

Pressure port (A)

Volumetric efficiency for HFA

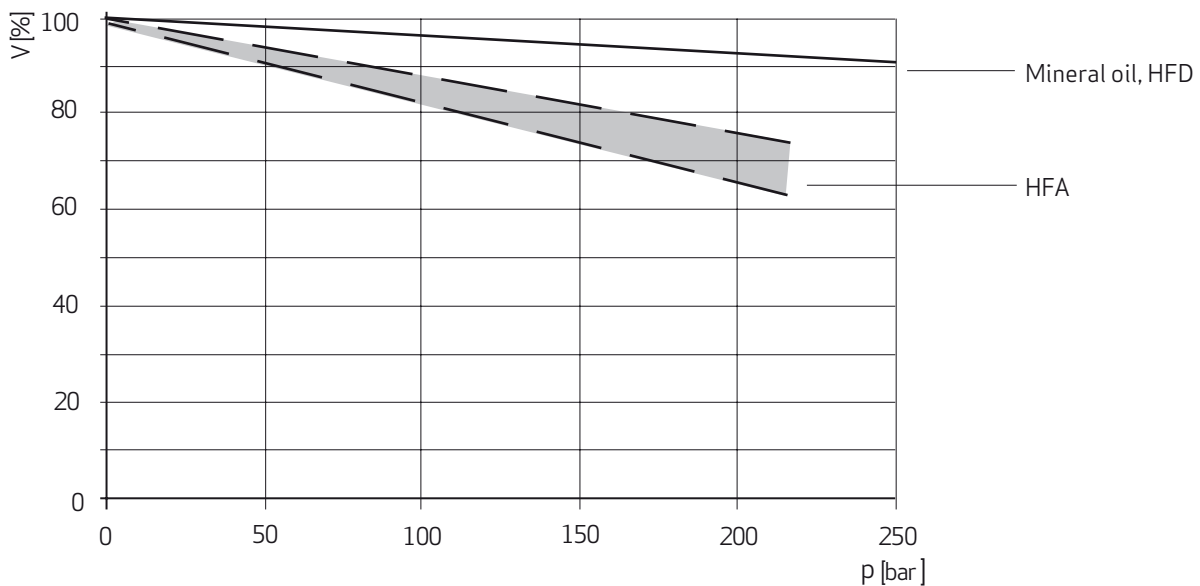

RADIAL PISTON PUMPS RKP-II FOR LOW-FLAMMABILITY FLUIDS

MULTIPLE PUMPS

RKP – MULTIPLE PUMPS

Additional pumps can be tandem-mounted on the radial piston pump, so that all pump stages can be driven by the same shaft. Radial piston pumps (the same size or smaller than the first pump stage) can be mounted directly.

Other pumps may be added on using adapter flanges for SAE-A, SAE-B or SAE-C respectively. For the maximum permitted through-drive torque for driving add-on pumps, please refer to the table below.

Adding on RKP, SAE-A, SAE-B or SAE-C adapters Permissible through-drive torques

Pump stage 1	Pump stage 2						
	RKP-II				SAE-A	SAE-B	SAE-C
Size (cm ³ /rev) (cu.in/rev)	19 (1.16)	32 (1.95) 45 (2.75)	63 (3.84) 80 (4.88) 100 (6.10)	140 (8.54)			
19 (1.16)	90 Nm (66.4 lbf ft)	–	–	–	90 Nm (66.4 lbf ft)	–	–
32/45 (1.95/2.75)	185 Nm (136.4 lbf ft)	185 Nm (136.4 lbf ft)	–	–	110 Nm (81.1 lbf ft)	185 Nm (136.4 lbf ft)	–
63/80/100 (3.84/4.88/6.10)	400 Nm (295.0 lbf ft)	400 Nm (295.0 lbf ft)	400 Nm (295.0 lbf ft)	–	110 Nm (81.1 lbf ft)	280 Nm (206.5 lbf ft)	400 Nm (295.0 lbf ft)
140 (8.54)	400 Nm (295.0 lbf ft)	400 Nm (295.0 lbf ft)	400 Nm (295.0 lbf ft)	620 Nm (457.3 lbf ft)	110 Nm (81.1 lbf ft)	280 Nm (206.5 lbf ft)	620 Nm (457.3 lbf ft)

The through-drive torque required to drive add-on pumps is determined by reference to the following variables:

V [cm ³ /rev]	Displacement
p [bar]	Pressure
η _{hm} [%]	Hydro-mechanical efficiency
M [Nm]	Through-drive torque

Example

Referred to a pump combination RKP63 + RKP 63 + RKP32 + AZP 16 280 bar, 210 bar, 150 bar, 50 bar this means:

Design of 1st through-drive

The pressure and flow of the 1st pump stage are irrelevant to the torque transferred by the through-drive. This torque can be calculated using the above formula:

$$M_1 = 1.59 \cdot \left(\frac{V_2 \cdot p_2}{\eta_{hm2}} + \frac{V_3 \cdot p_3}{\eta_{hm3}} + \frac{V_4 \cdot p_4}{\eta_{hm4}} \right)$$

$$M_1 = 1.59 \cdot (63 \cdot 210 / 95 + 32 \cdot 150 / 93 + 16 \cdot 50 / 90) \text{ Nm}$$

$$M_1 = 318 \text{ Nm (234.5 lbf ft)}$$

The value 318 Nm (234.5 lbf ft) is below the threshold value of 400 Nm (295.0 lbf ft) specified in the above table for mounting an RKP 63 on another RKP 63.

Through-drive torque from pump stage 1 to 2:

$$M_1 = 1.59 \cdot \sum_{i=2}^n \frac{V_i \cdot p_i}{\eta_{hmi}}$$

Design of 2nd through-drive

$$M_2 = 1.59 \cdot \left(\frac{V_3 \cdot p_3}{\eta_{hm3}} + \frac{V_4 \cdot p_4}{\eta_{hm4}} \right)$$

$$M_2 = 1.59 \cdot (32 \cdot 150 / 93 + 16 \cdot 50 / 90) \text{ Nm}$$

$$M_2 = 96 \text{ Nm (70.8 lbf ft)}$$

Likewise, the value 96 Nm (70.8 lbf ft) lies below the relevant threshold value of 400 Nm (295.0 lbf ft) for the through-drive from an RKP-II 63 to an RKP-II 32.

Design of 3rd through-drive

Similarly, a value of 14 Nm (10.3 lbf ft) is obtained for the torque required to drive the add-on gear pump. Thus, the through-drives for this pump combination are permissible with the stated pressures.

RADIAL PISTON PUMPS RKP-II FOR LOW-FLAMMABILITY FLUIDS

MULTIPLE PUMPS

Radial piston pump with through-drive and tandem-mounted radial piston pump

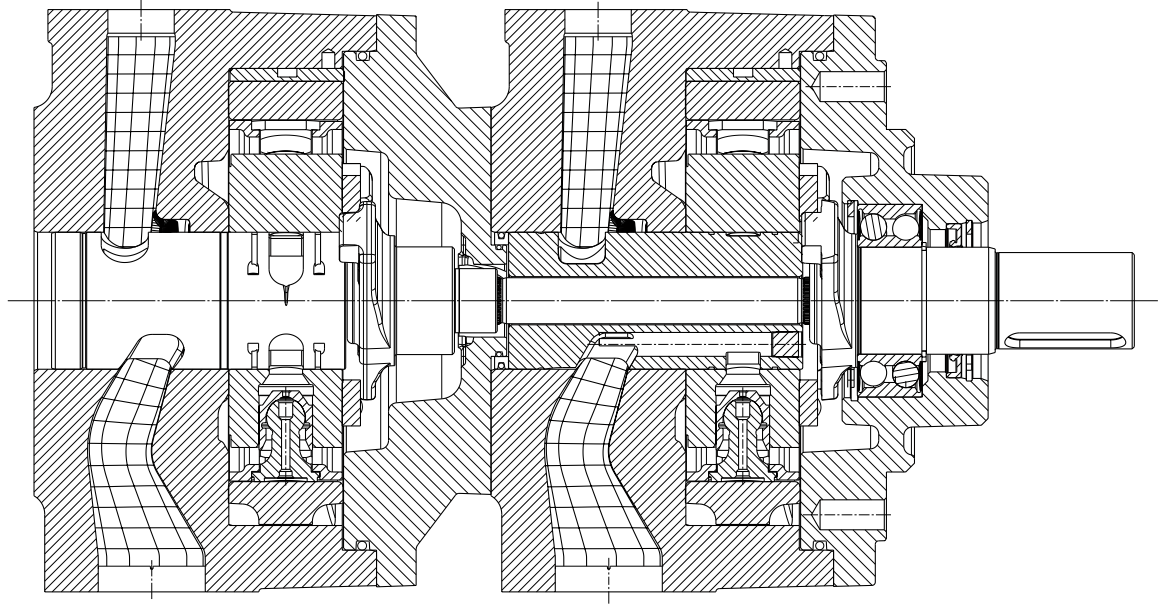

Radial piston pump with tandem-mounted gear pump using SAE-A adapter

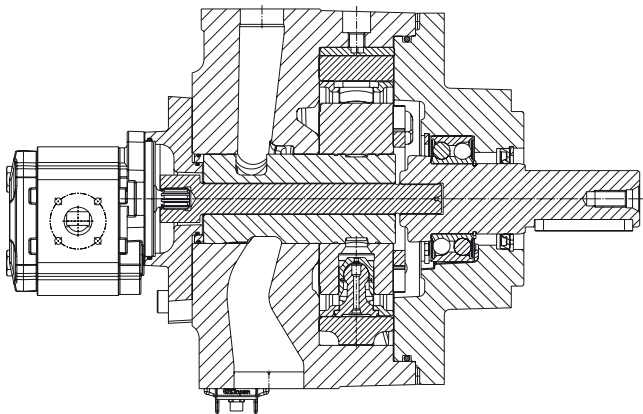

Radial piston pump with tandem-mounted gear pump using SAE-B adapter

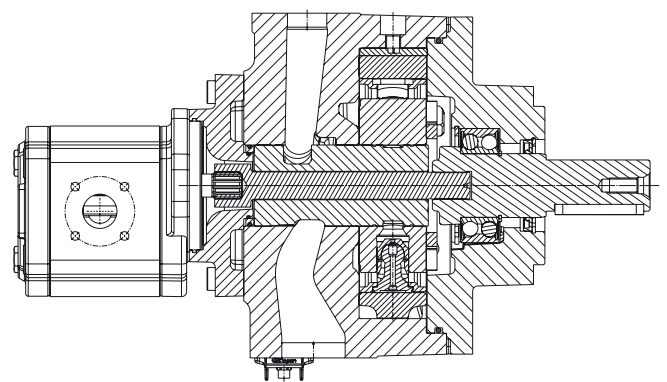

RADIAL PISTON PUMPS RKP-II FOR LOW-FLAMMABILITY FLUIDS

MULTIPLE PUMPS

ADAPTER FLANGE FOR FITTING AN EXTERNAL PUMP WITH SAE-A FLANGE AND 9-TOOTH SHAFT

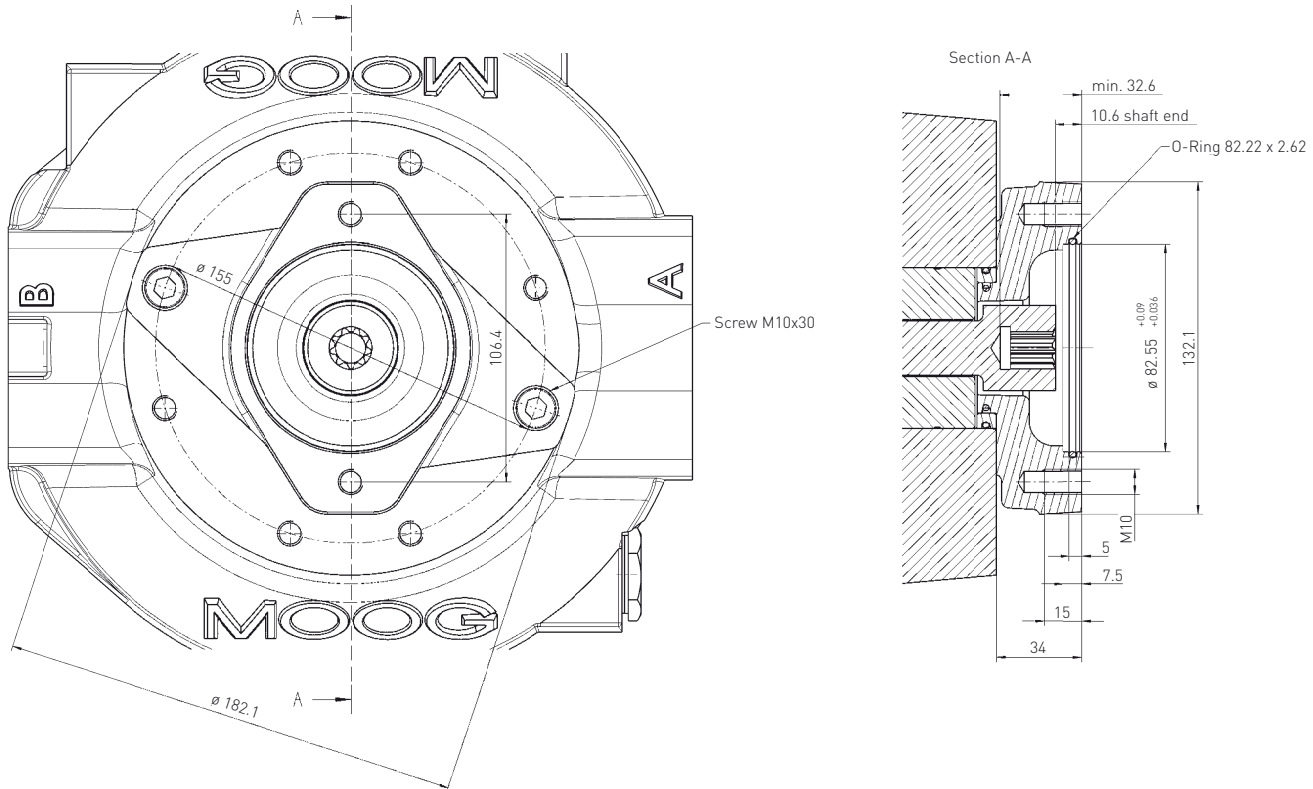

Flange code: 82-2

Shaft code: 16-4

Toothing to: ANSI B92.1 9T 16/32 DP Flat root side fit

Conditions for attachment: RKP with heavy-duty through-drive

Adapter including through-drive shaft, seals (HNB-R), intermediate ring for RKP 63-140 and 2 fastening screws.

RKP 19	CA41832-001-00
RKP 32/45	CA51553-001-00
RKP 63/80/100	CA64727-001-00
RKP 140	CA64728-001-00

RADIAL PISTON PUMPS RKP-II FOR LOW-FLAMMABILITY FLUIDS

MULTIPLE PUMPS

ADAPTER FLANGE FOR FITTING AN EXTERNAL PUMP WITH SAE-B FLANGE ACCORDING TO ISO 3019-1 AND 13-TOOTH SHAFT

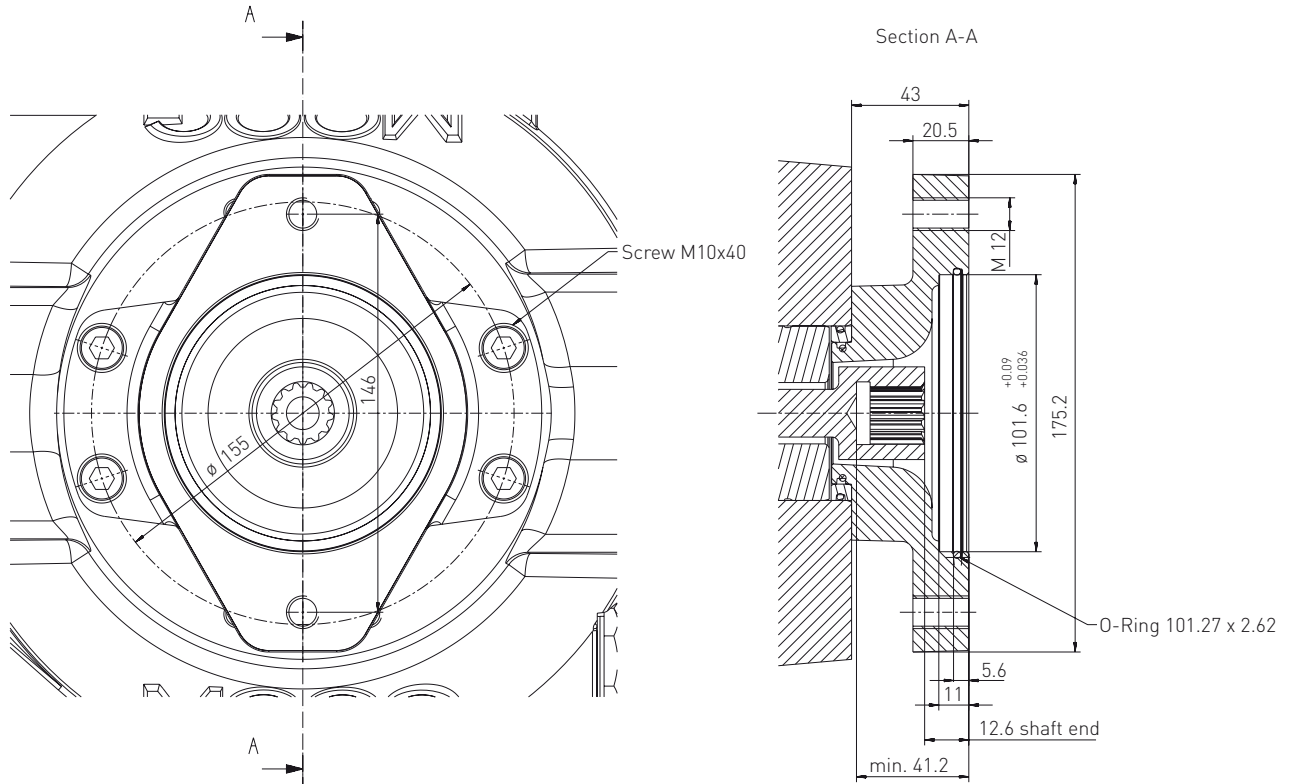

Flange code: 101-2

Shaft code: 22-4

Toothing to: ANSI B92.1 13T 16/32 DP Flat root side fit

Conditions for attachment: RKP with heavy-duty through-drive

Adapter including through-drive shaft, seals (HNB-R), intermediate ring for RKP 63-140 and 2 fastening screws.

RKP 32/45	CA36273-001
RKP 63/80/100	CA34793-001
RKP 140	CA50487-001

RADIAL PISTON PUMPS RKP-II FOR LOW-FLAMMABILITY FLUIDS

MULTIPLE PUMPS

ADAPTER FLANGE FOR FITTING AN EXTERNAL PUMP WITH SAE-C FLANGE ACCORDING TO ISO 3019-1 AND 14-TOOTH SHAFT

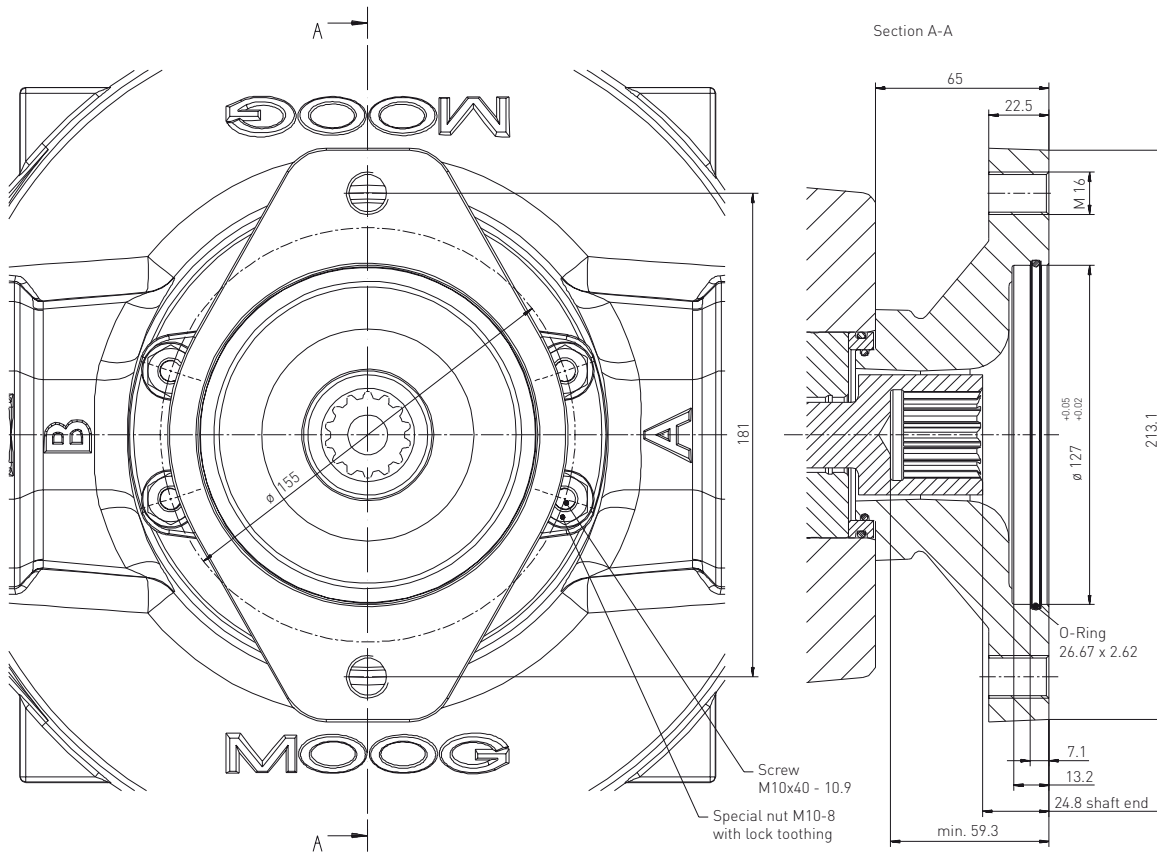

Flange code: 127-2

Shaft code: 32-4

Toothing to: ANSI B92.1 14T 12/24 DP Flat root side fit

Conditions for attachment: RKP with heavy-duty through-drive

Adapter including through-drive shaft, seals (HNB-R), intermediate ring for RKP 140 and 4 fastening screws and special nut.

RKP 63/80/100	CA64621-001
RKP 140	CA64622-001

RADIAL PISTON PUMPS RKP-II FOR LOW-FLAMMABILITY FLUIDS

COMPENSATOR OPTIONS

COMPENSATOR OPTIONS

A wide range of compensator options can be realized with the RKP-II, thereby guaranteeing maximum flexibility. The following options are described in more detail in Appendix A.

Compensator options	Description/characteristics/application
1. Adjustable pressure compensator, Type F	For constant pressure systems with a fixed pressure setting.
2. Remote pressure compensator, Type H1	For constant or variable pressure systems with remote pressure
3. Pressure compensator with Mooring control, Type H2	For constant pressure systems with a variable pressure setting for mooring control
4. Combined pressure and flow compensator, Type J	For displacement systems with a variable flow and load sensing pressure control (hydromechanical compensator concept).
5. Combined pressure and flow compensator with P-T control notch, Type R	As 4. with additional active reduction of pressure peaks in the event of dynamic control process
6. Mechanical stroke adjustment, Type B	For displacement systems with a fixed displacement that may be manually adjusted as needed.
7. Servo control, Type C1	Adjustment of displacement using a hand lever or an actuator.
8. Electro-hydraulically adjustable compensator with digital on-board electronics, Type D	For displacement systems with a variable flow and load sensing pressure control

Radial piston pump for potentially explosive atmospheres

In conjunction with all the hydraulic/mechanical compensators the radial piston pump is available in a version for potentially explosive atmospheres. This pump can be installed and operated in an environment conforming to Group II, Category 2 GD, Explosion Groups II A, II B and II C. The following range of application according to the EC Directive 94/9/EC is permissible:

 II --/2 GD +135 °C (+275 °F) (T4) –15 °C (+5 °F) ≤ Ta
≤ +60 °C (+140 °F)

RADIAL PISTON PUMPS RKP-II FOR LOW-FLAMMABILITY FLUIDS

TYPE CODE HFA/HFB (1)

THE TYPE CODE DESCRIBES PUMP OPTIONS

Design interfaces (flange, shaft end and ports), hydraulic parameters (volume flow, operating pressure and hydraulic fluid), and compensator/control options are defined.

EXAMPLE

Position no.	1		2	3	4			
Drive	HP	-	R	18	B7	-		
Position no. (pump)	5	6	7	8	9	10	11	12
Pump 1	RKP	100	T	A	12	J1	Y	00
Pump 2	RKP	063	K	A	12	F2	Z	00
Pump 3	RKP	019	S	A	12	B1	Z	00

	Drive			
Pos.	1	2	3	4
Sym.	HP	R	18	B7

Radial piston pump							
5	6	7	8	9	10	11	12
RKP	100	T	A	12	D1	Z	00

Radial piston pump							
5	6	7	8	9	10	11	12
RKP	063	K	A	12	D2	Z	00

Additional Pump stage							
5	6	7	8	9	10	11	12
AZP	008	R	A	05	TP	0	00

Type code for version for HFA/HFB fluid

Position	Sym.	Drive
1	HP HK HZ	Code Hydraulic pump RKP for potentially explosive atmospheres Pump with special features
2	R L	Direction of rotation Clockwise, looking at drive shaft Counterclockwise, looking at drive shaft
3	18	Speed Maximum speed for low-noise operation or rated speed for power-controlled pumps, e.g. 18 ± 1,800 rpm
4	A7	Drive flange Straight key according to ISO 2491, 4-hole ISO flange according to ISO 3019/2 (metric)

RADIAL PISTON PUMPS RKP-II FOR LOW-FLAMMABILITY FLUIDS

TYPE CODE HFA/HFB (2)

Position	Sym.	Radial piston pump
5	RKP AZP DS1	Pump type Radial piston pump, variable displacement Moog gear pump with SAE-A and SAE-B flange Attachment of other pumps Through-drive for RKP attachment and adapter flange for SAE-A, SAE-B and SAE-C
6	019 032 063 080 005 008 011 016 019 023 031 033 044 050	Displacement RKP-II 19 cm ³ /rev (1.16 cu.in/rev) 32 cm ³ /rev (1.95 cu.in/rev) 63 cm ³ /rev (3.84 cu.in/rev) 80 cm ³ /rev (4.88 cu.in/rev) Displacement and attachment flange of Moog gear pumps (AZP) 5 cm ³ /rev (0.31 cu.in/rev) SAE-A 8 cm ³ /rev (0.49 cu.in/rev) SAE-A 11 cm ³ /rev (0.67 cu.in/rev) SAE-A 16 cm ³ /rev (0.98 cu.in/rev) SAE-A 19 cm ³ /rev (1.16 cu.in/rev) SAE-A 23 cm ³ /rev (1.40 cu.in/rev) SAE-A 31 cm ³ /rev (1.89 cu.in/rev) SAE-A 33 cm ³ /rev (2.01 cu.in/rev) SAE-B 44 cm ³ /rev (2.68 cu.in/rev) SAE-B 50 cm ³ /rev (3.05 cu.in/rev) SAE-B
7	K S R	Pump ports Medium-pressure series (to 280 bar (4,000 psi)) sizes 32, 45, 63 and 80 cm ³ /rev (1.95, 2.75, 3.84 and 4.88 cu.in/rev) Medium-pressure series (to 280 bar (4,000 psi)) size 19 cm ³ /rev (1.16 cu.in/rev) German 4 bolt flange (only for gear pumps)
8	A	Hydraulic fluid HFA (oil in water)
9	12	Operating pressure Maximum operating pressure, e.g. 12 ± 120 bar (1,740 psi)
10	B1 C1 D1 D2 F1 F2 G1 G2 H1 J1 J2 TP	Control/Compensators Mechanical stroke adjustment (V = constant) Servo control RKP-D (electro-hydraulic control with digital on-board electronics), analog or digital activation and internal pressure supply RKP-D (electro-hydraulic control with digital on-board electronics), analog or digital activation and external pressure supply Adjustable pressure compensator 30 bar to 105 bar (435 psi to 1,520 psi) Adjustable pressure compensator 80 bar to 280 bar (1,160 psi to 4,000 psi) Adjustable pressure compensator, lockable 30 bar to 150 bar (435 psi to 2,175 psi) Adjustable pressure compensator, lockable 80 bar to 350 bar (1,160 psi to 5,000 psi) Hydraulically actuated pressure compensator Combined pressure and flow compensator Δp = 10 bar (145 psi) Combined pressure and flow compensator Δp = 20 bar (290 psi) Gear pump: without compensator
11	Z Y O	Additional equipment No accessories Maximum flow limiter Only at gear pump
12	00 00 01 05 to 50	Additional information: General: Without For compensators D1 and D2: Actual value 4 mA to 20 mA Actual value 2 V to 10 V For tandem gear pumps: Displacement of the 2nd gear pump stage 5 cm ³ /rev (0.31 cu.in/rev) to 50 cm ³ /rev (3.05 cu.in/rev)

RADIAL PISTON PUMPS RKP-II FOR LOW-FLAMMABILITY FLUIDS

TYPE CODE HFC (1)

Position	Sym.	Drive
1	HP HK HZ	Code Hydraulic pump RKP for potentially explosive atmospheres Pump with special features
2	R L	Direction of rotation Clockwise, looking at drive shaft Counterclockwise, looking at drive shaft
3	18	Speed Maximum speed for low-noise operation or rated speed for power-controlled pumps, e.g. 18 $\hat{=}$ 1,800 rpm
4	A1 B1 A7 B7 C3 D3 XX	Drive flange Straight key according to ISO 2491, metric round flange (not for RKP 140) Involute spline according to DIN 5482, metric round flange (not for RKP 140) Straight key according to ISO 2491, 4-hole ISO flange according to ISO 3019/2 (metric) Involute spline according to DIN 5480, 4-hole ISO flange according to ISO 3019/2 (metric) Straight key according to SAE 744 C, 2/4-hole SAE flange according to ISO 3019/1 (imperial) Involute spline according to SAE 744 C (ISO 3019/1), 2/4-hole SAE flange according to ISO 3019/1 (imperial) Intermediate flange RKP/RKP
5	RKP AZP DS1	Pump type Radial piston pump, variable displacement Moog gear pump with SAE-A and SAE-B flange Attachment of other pumps Through-drive for RKP attachment and adapter flange for SAE-A, SAE-B and SAE-C
6	019 032 045 063 080 100 140 005 008 011 016 019 023 031 033 044 050	Displacement RKP-II 19 cm ³ /rev (1.16 cu.in/rev) 32 cm ³ /rev (1.95 cu.in/rev) 45 cm ³ /rev (2.75 cu.in/rev) 63 cm ³ /rev (3.84 cu.in/rev) 80 cm ³ /rev (4.88 cu.in/rev) 100 cm ³ /rev (6.10 cu.in/rev) 140 cm ³ /rev (8.54 cu.in/rev) Displacement and attachment flange of Moog gear pumps (AZP) 5 cm ³ /rev (0.31 cu.in/rev) SAE-A 8 cm ³ /rev (0.49 cu.in/rev) SAE-A 11 cm ³ /rev (0.67 cu.in/rev) SAE-A 16 cm ³ /rev (0.98 cu.in/rev) SAE-A 19 cm ³ /rev (1.16 cu.in/rev) SAE-A 23 cm ³ /rev (1.40 cu.in/rev) SAE-A 31 cm ³ /rev (1.89 cu.in/rev) SAE-A 33 cm ³ /rev (2.01 cu.in/rev) SAE-B 44 cm ³ /rev (2.68 cu.in/rev) SAE-B 50 cm ³ /rev (3.05 cu.in/rev) SAE-B
7	K T S R	Pump ports Medium-pressure series (to 280 bar (4,000 psi)) sizes 32, 45, 63 and 80 cm ³ /rev (1.95, 2.75, 3.84 and 4.88 cu.in/rev) Medium-pressure series (to 280 bar (4,000 psi)) sizes 100 cm ³ /rev (6.10 cu.in/rev) and 140 cm ³ /rev (8.54 cu.in/rev) Medium-pressure series (to 280 bar (4,000 psi)) size 19 cm ³ /rev (1.16 cu.in/rev) German 4 bolt flange (only for gear pumps)
8	C	Hydraulic fluid HFC (water glycol)

RADIAL PISTON PUMPS RKP-II FOR LOW-FLAMMABILITY FLUIDS

TYPE CODE HFC (2)

Position	Sym.	Radial piston pump
9	21	Operating pressure Maximum operating pressure, e.g. 21 $\hat{=}$ 210 bar (3,000 psi)
10	B1 C1 D1 ¹ D2 ¹ D3 ¹ D4 ¹ D5 ¹ D6 ¹ D7 ¹ D8 ¹ F1 F2 H1 J1 J2 R1 TP	Control/Compensators Mechanical stroke adjustment (V = constant) Servo control RKP-D (electro-hydraulic control with digital on-board electronics), analog or digital activation and internal pressure supply RKP-D (electro-hydraulic control with digital on-board electronics), analog or digital activation and external pressure supply RKP-D with external pressure supply, usable for hybrid operation RKP-D with internal pressure supply, usable for hybrid operation RKP-D with internal pressure supply usable for master/slave operation RKP-D with external pressure supply usable for master/slave operation RKP-D with external pressure supply usable for master/slave and hybrid operation RKP-D with internal pressure supply usable for master/slave and hybrid operation Adjustable pressure compensator 30 bar to 105 bar (435 psi to 1,520 psi) Adjustable pressure compensator 80 bar to 280 bar (1,160 psi to 4,000 psi) Hydraulically actuated pressure compensator Combined pressure and flow compensator $\Delta p = 10$ bar (145 psi) Combined pressure and flow compensator $\Delta p = 20$ bar (290 psi) Combined pressure and flow compensator with P-T control notch Gear pump: without compensator
11	Z Y 0	Additional equipment No accessories Maximum flow limiter Only at gear pump
12	00 00 01 05 to 50	Additional information General: Without For compensators D1 to D8: Actual value 4 mA to 20 mA Actual value 2 V to 10 V For tandem gear pumps: Displacement of the 2nd gear pump stage 5 cm ³ /rev (0.31 cu.in/rev) to 50 cm ³ /rev (3.05 cu.in/rev)

¹ See Supplementary Catalog RKP with digital control (RKP-D)

RADIAL PISTON PUMPS RKP-II FOR LOW-FLAMMABILITY FLUIDS

TYPE CODE HFD (1)

Pos.	Sym.	Drive
1	HP HK HZ	Code Hydraulic pump RKP for potentially explosive atmospheres Pump with special features
2	R L	Direction of rotation Clockwise, looking at drive shaft Counterclockwise, looking at drive shaft
3	18	Speed Maximum speed for low-noise operation or rated speed for power-controlled pumps, e.g. 18 $\hat{=}$ 1,800 rpm
4	A1 B1 A7 B7 C3 D3 XX	Drive flange Straight key according to ISO 2491, metric round flange (not for RKP 140) Involute spline according to DIN 5482, metric round flange (not for RKP 140) Straight key according to ISO 2491, 4-hole ISO flange according to ISO 3019/2 (metric) Involute spline according to DIN 5480, 4-hole ISO flange according to ISO 3019/2 (metric) Straight key according to SAE 744 C, 2/4-hole SAE flange according to ISO 3019/1 (imperial) Involute spline according to SAE 744 C (ISO 3019/1), 2/4-hole SAE flange according to DIN ISO 3019/1 (imperial) Intermediate flange RKP/RKP
5	RKP AZP DS1	Pump type Radial piston pump, variable displacement Moog gear pump with SAE-A and SAE-B flange Attachment of other pumps Through-drive for RKP attachment and adapter flange for SAE-A, SAE-B and SAE-C
6	019 032 045 063 080 100 140 005 008 011 016 019 023 031 033 044 050	Displacement RKP-II 19 cm ³ /rev (1.16 cu.in/rev) 32 cm ³ /rev (1.95 cu.in/rev) 45 cm ³ /rev (2.75 cu.in/rev) 63 cm ³ /rev (3.84 cu.in/rev) 80 cm ³ /rev (4.88 cu.in/rev) 100 cm ³ /rev (6.10 cu.in/rev) 140 cm ³ /rev (8.54 cu.in/rev) Displacement and attachment flange of Moog gear pumps (AZP) 5 cm ³ /rev (0.31 cu.in/rev) SAE-A 8 cm ³ /rev (0.49 cu.in/rev) SAE-A 11 cm ³ /rev (0.67 cu.in/rev) SAE-A 16 cm ³ /rev (0.98 cu.in/rev) SAE-A 19 cm ³ /rev (1.16 cu.in/rev) SAE-A 23 cm ³ /rev (1.40 cu.in/rev) SAE-A 31 cm ³ /rev (1.89 cu.in/rev) SAE-A 33 cm ³ /rev (2.01 cu.in/rev) SAE-B 44 cm ³ /rev (2.68 cu.in/rev) SAE-B 50 cm ³ /rev (3.05 cu.in/rev) SAE-B
7	K T T S H R	Pump ports Medium-pressure series (to 280 bar (4,000 psi)) sizes 32, 45, 63 and 80 cm ³ /rev (1.95, 2.75, 3.84 and 4.88 cu.in/rev) Medium-pressure series (to 280 bar (4,000 psi)) sizes 100 cm ³ /rev (6.10 cu.in/rev) and 140 cm ³ /rev (8.54 cu.in/rev) High-pressure series (to 350 bar (5,000 psi)) sizes 32, 45, 63 and 80 cm ³ /rev (1.95, 2.75, 3.84 and 4.88 cu.in/rev) Medium-pressure series (to 280 bar (4,000 psi)) size 19 cm ³ /rev (1.16 cu.in/rev) High-pressure series (to 280 bar (4,000 psi)) size 19 cm ³ /rev (1.16 cu.in/rev) German 4 bolt flange (only for gear pumps)

RADIAL PISTON PUMPS RKP-II FOR LOW-FLAMMABILITY FLUIDS

TYPE CODE HFD (2)

Pos.	Sym.	Radial piston pump
8	D	Hydraulic fluid HFD (synthetic ester)
9	28 35	Operating pressure Maximum operating pressure, e.g. 28 $\hat{=}$ 280 bar (4,000 psi) Maximum operating pressure, e.g. 35 $\hat{=}$ 350 bar (5,000 psi)
10	B1 C1 D1 ¹ D2 ¹ D3 ¹ D4 ¹ D5 ¹ D6 ¹ D7 ¹ D8 ¹ F1 F2 H1 J1 J2 R1 TP	Control/Compensators Mechanical stroke adjustment (V = constant) Servo control RKP-D (electro-hydraulic control with digital on-board electronics), analog or digital activation and internal pressure supply RKP-D (electro-hydraulic control with digital on-board electronics), analog or digital activation and external pressure supply RKP-D with external pressure supply, usable for hybrid operation RKP-D with internal pressure supply, usable for hybrid operation RKP-D with internal pressure supply usable for master/slave operation RKP-D with external pressure supply usable for master/slave operation RKP-D with external pressure supply usable for master/slave and hybrid operation RKP-D with internal pressure supply usable for master/slave and hybrid operation Adjustable pressure compensator 30 bar to 105 bar (435 psi to 1,520 psi) Adjustable pressure compensator 80 bar to 280 bar (1,160 psi to 4,000 psi) Hydraulically actuated pressure compensator Combined pressure and flow compensator $\Delta p = 10$ bar (145 psi) Combined pressure and flow compensator $\Delta p = 20$ bar (290 psi) Combined pressure and flow compensator with P-T control notch Gear pump
11	Z Y 0	Additional equipment No accessories Maximum flow limiter Only at gear pump
12	00 00 01 05 to 50	Additional information General: Without For compensators D1 to D8: Actual value 4 mA to 20 mA Actual value 2 V to 10 V For tandem gear pumps: Displacement of the 2nd gear pump stage 5 cm ³ /rev (0.31 cu.in/rev) to 50 cm ³ /rev (3.05 cu.in/rev)

¹ See Supplementary Catalog RKP with digital control (RKP-D)

RADIAL PISTON PUMPS RKP-II FOR LOW-FLAMMABILITY FLUIDS

TECHNICAL INFORMATION

TECHNICAL INFORMATION

Important

The pump must be put into service by a trained hydraulic systems engineer.

Installation

The radial piston pump can be mounted in any position. No radial or axial forces are permitted to act on the drive shaft. The drive must therefore be effected via a flexible coupling. Only remove all the pump sealing plugs immediately before connecting the lines.

Ensure conditions of absolute cleanliness when installing. The use of cold drawn seamless steel pipes in accordance with DIN 2391 is recommended.

Suction line

A short suction line with a large inside diameter is required to ensure a short acting time and low noise.

Suction rate < 1.5 m/sec (< 4 ft 11 in/s).

Avoid sharp deviations and pipe couplings (risk of air intake and air separation, high flow resistance). Use bent pipes or hoses instead. The minimum permissible inlet pressure must be maintained.

Reduce the suction line only at the pump inlet. If a suction filter (min. 0.15 mm (0.006 in) mesh aperture) or an isolating valve is to be used, it must be installed below the fluid level.

Pressure line

Make sure the line is sufficiently secure. Check the screw tightening torques.

Drain line (L)

The upper drain port must be used for the drain line and the pipework is to be routed to ensure the housing is always full of fluid. The pipe should lead directly to the tank, separate from other return lines.

The end of the line must be located below the fluid level even when the fluid level is at its lowest in the tank.

Ensure the distance to the suction line is as large as possible. Do not fit a filter, cooler or non-return valve in the leakage oil line. The maximum recommended length is 3 meters (9 ft 10 in).

Pressure at the drain port maximum 2 bar (29,0 psi) absolute (1 bar (14.5 psi) gage pressure).

The recommended outside pipe diameters for drain lines (lightweight version) are:

RKP 19: 15 mm (0.59 in)

RKP 32 and 45: 18 mm (0.71 in)

RKP 63, 80, 100 and 140: 22 mm (0.87 in)

Flushing the housing

If the pump is operated at low pressure without flow for long periods ($t > 15$ min, $p < 30$ bar (< 435 psi), $Q = 0$ l/min (0 gpm)), pump sizes 63 cm³/rev (3.84 cu.in/rev) to 100 cm³/rev (6.10 cu.in/rev) must be flushed with approximately 4 l/min to 6 l/min (0.88 gpm to 1.32 gpm) to dissipate the heat generated. The 140 cm³/rev (8.54 cu.in/rev) pump must always be flushed with 6 l/min to 8 l/min (1.32 gpm to 1.76 gpm). The flushing line to the pump must be connected to the lower drain port. On pumps for HFC fluid the housing is flushed when the bearing is flushed.

Noise generation

Radial piston pumps have a low primary noise level. However, the level of noise generated by the entire hydraulic unit is very much dependent on the mounting of the pump and on the routing of the lines.

Prevent structure-borne noise from being transmitted to radiating machine components covering a large area by:

- mounting the pump using an anti-vibration flange
- using flexible hoses instead of solid pipes
- clamping the pipework with elastic insert clamps

Connections

Suction line to port A and pressure line from port B.

Except for RKP 19 counterclockwise: suction port B, pressure port A.

Putting into service

Do not start up the pump without hydraulic fluid. Before switching on, the pump housing must be filled with hydraulic fluid using the drain port.

Jog-start the electric motor to check the correct direction of rotation. Run the pump at low pressure until the hydraulic system has been fully de-aerated.

When putting pumps for HF fluids into operation, the system must be run at low pressure of between 30 bar to 50 bar (435 psi to 725 psi) for approximately 1 hour.

Important

The oil temperature in the tank must not exceed the temperature of the pump by more than 25 °C (77 °F). If this should occur, the pump must be jog-started for intervals of approximately 1 to 2 seconds until the pump casing has heated up. When changing a pump, clean the suction pipe, drain line and tank. Refill the tank with filtered oil only.

RADIAL PISTON PUMPS RKP-II FOR LOW-FLAMMABILITY FLUIDS

APPENDIX A – COMPENSATOR OPTIONS

1. ADJUSTABLE PRESSURE COMPENSATOR, F1, F2

Pressure range:

F1: 30 bar to 105 bar (435 psi to 1,520 psi)

F2: 80 bar to 350 bar (1,160 psi to 5,000 psi)

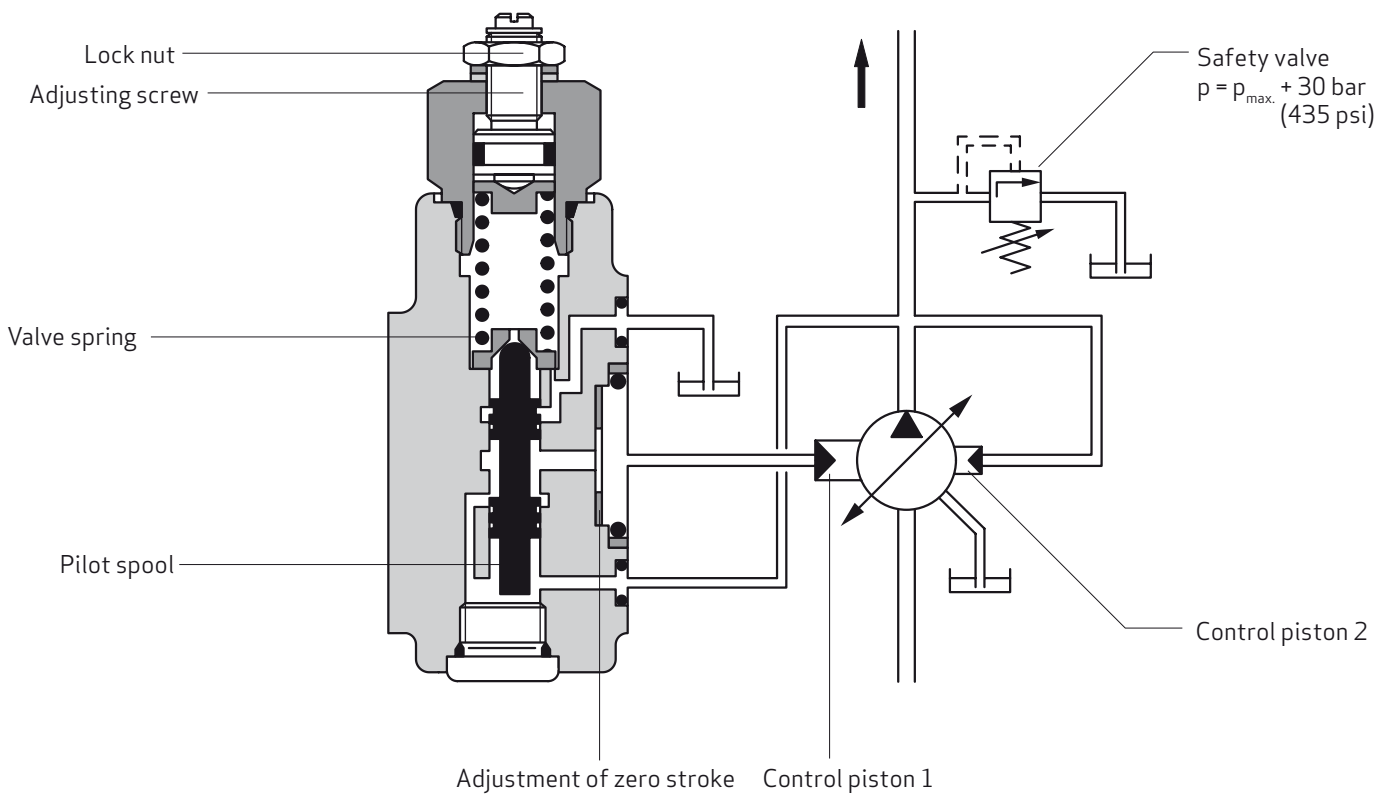
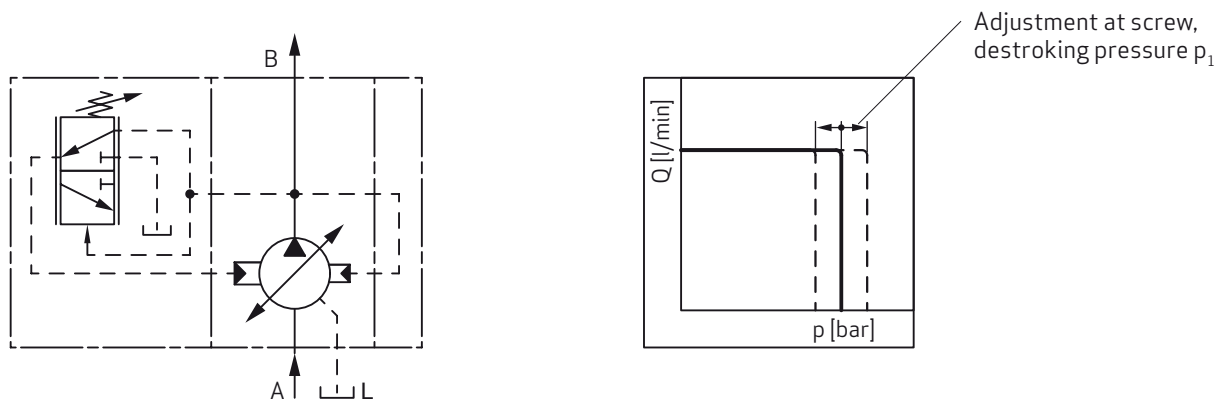

RADIAL PISTON PUMPS RKP-II FOR LOW-FLAMMABILITY FLUIDS

APPENDIX A – COMPENSATOR OPTIONS

2. Remote pressure compensator H1

Pressure pilot valve:

Manual adjustable or proportional pressure valve

$Q = 0.5 \text{ l/min to } 1.5 \text{ l/min}$ (0.11 gpm to 0.33 gpm)

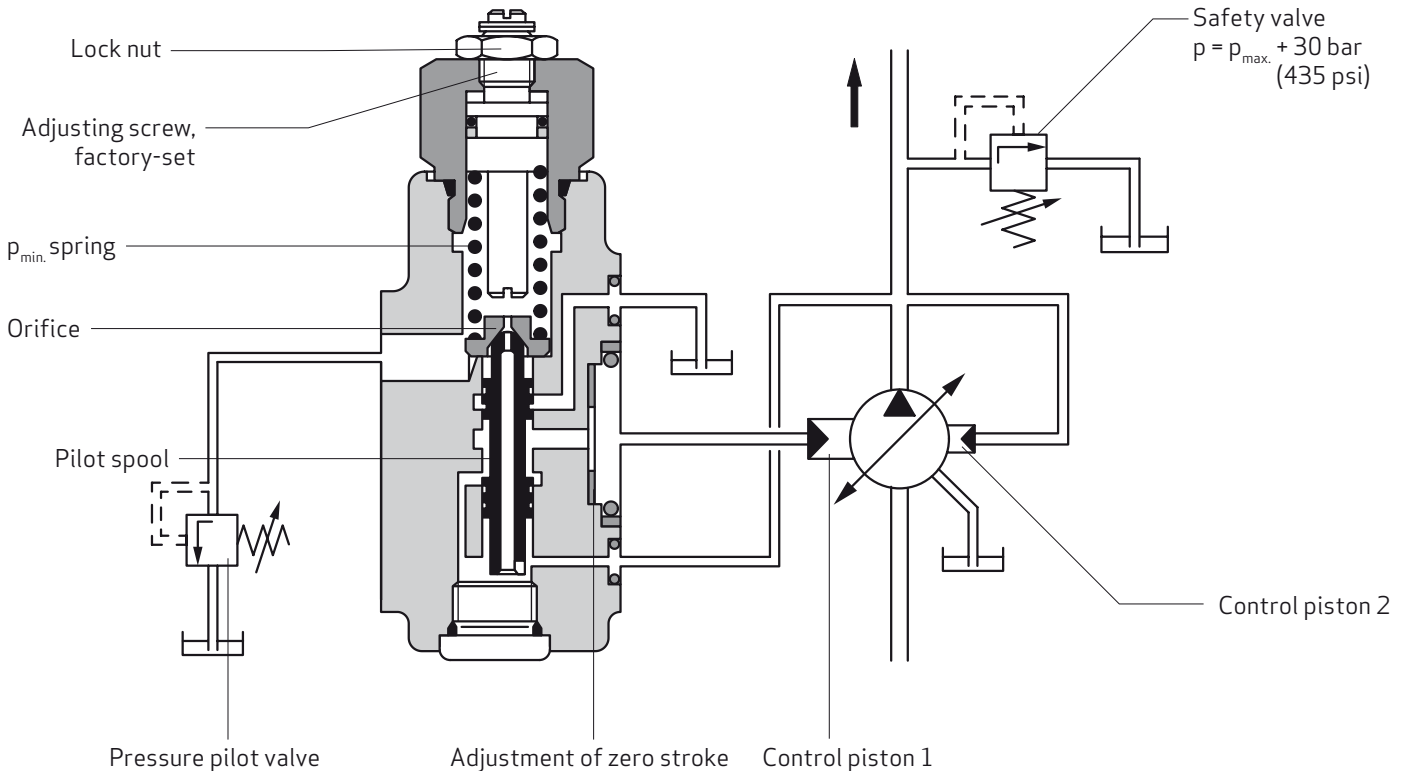
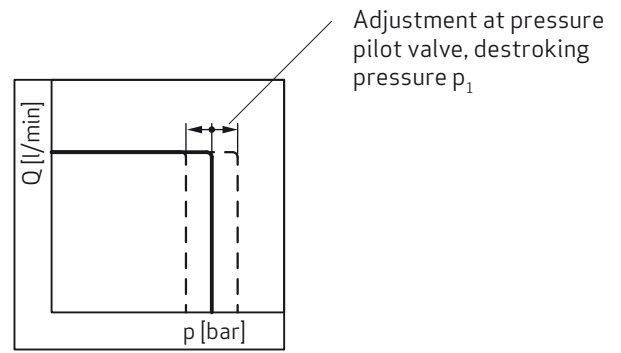
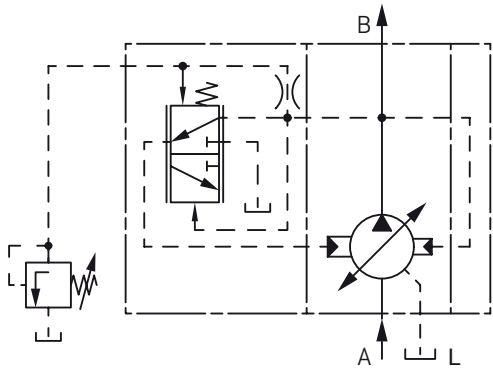

RADIAL PISTON PUMPS RKP-II FOR LOW-FLAMMABILITY FLUIDS

APPENDIX A – COMPENSATOR OPTIONS

3. COMBINED PRESSURE AND FLOW COMPENSATOR (“load sensing”) J1

Metering throttle:

Manual adjustable throttle valve or proportional throttle valve.

Pressure pilot valve:

Manual adjustable or proportional pressure valve
 $Q = 0.5 \text{ l/min to } 1.5 \text{ l/min (0.22 gpm to } 0.33 \text{ gpm)}$

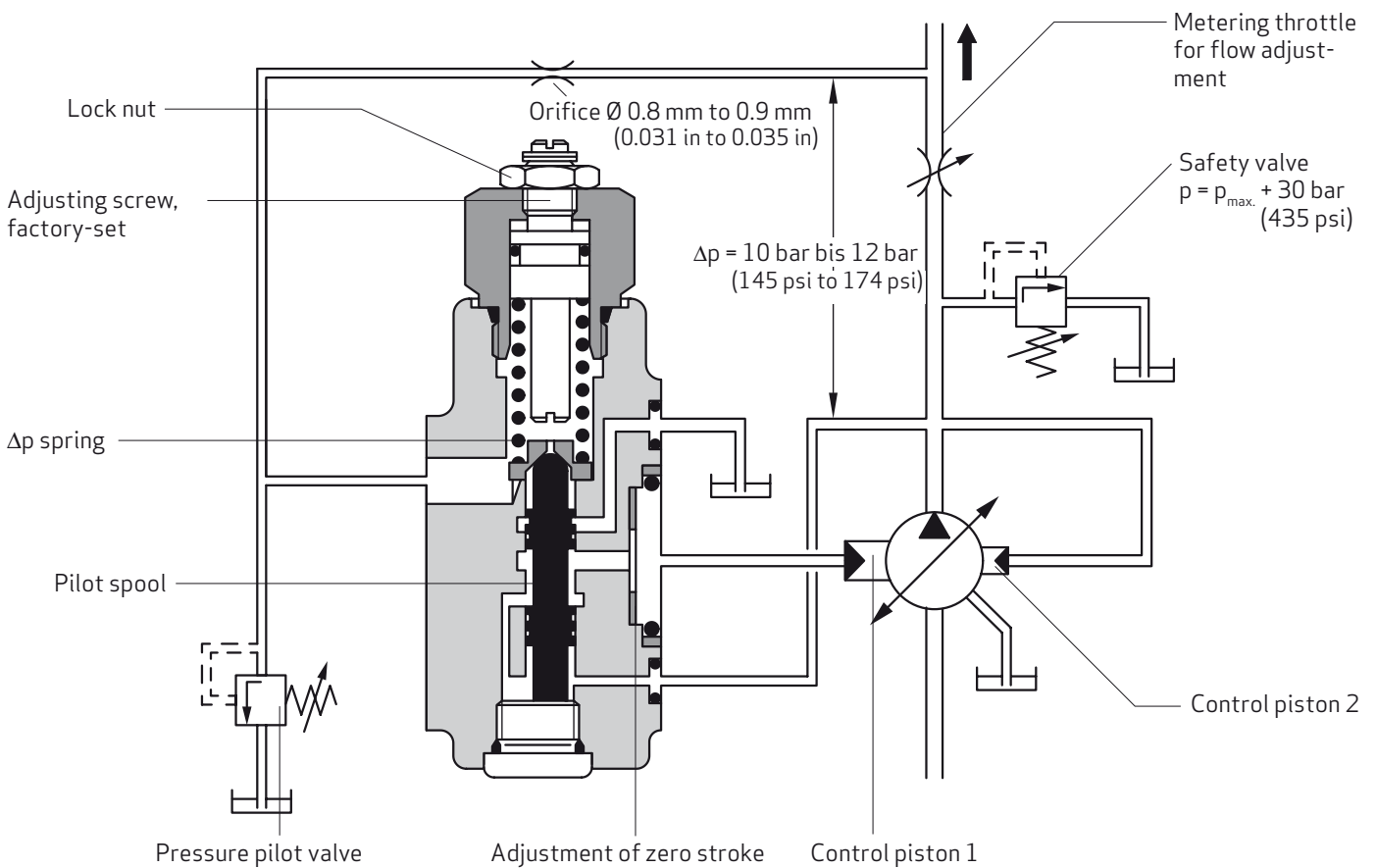
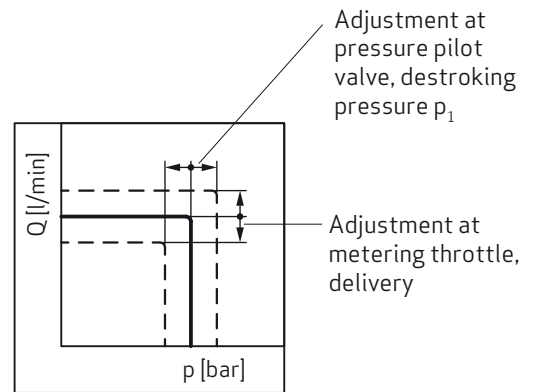
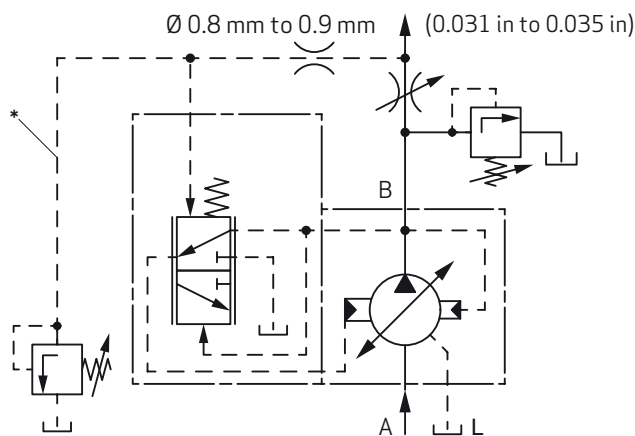

* Recommendation: Hose for pilot oil line, see Page 45

RADIAL PISTON PUMPS RKP-II FOR LOW-FLAMMABILITY FLUIDS

APPENDIX A – COMPENSATOR OPTIONS

4. MECHANICAL STROKE ADJUSTMENT, B 1

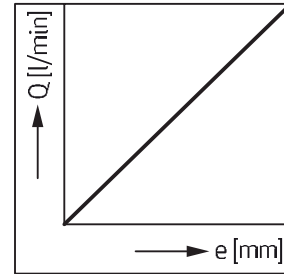
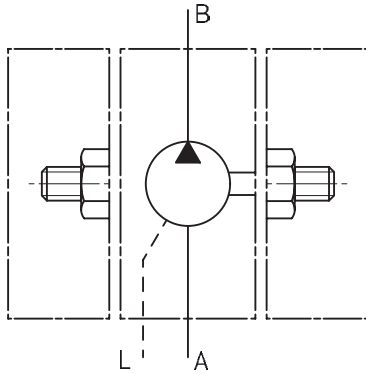

Eccentricity of stroke ring

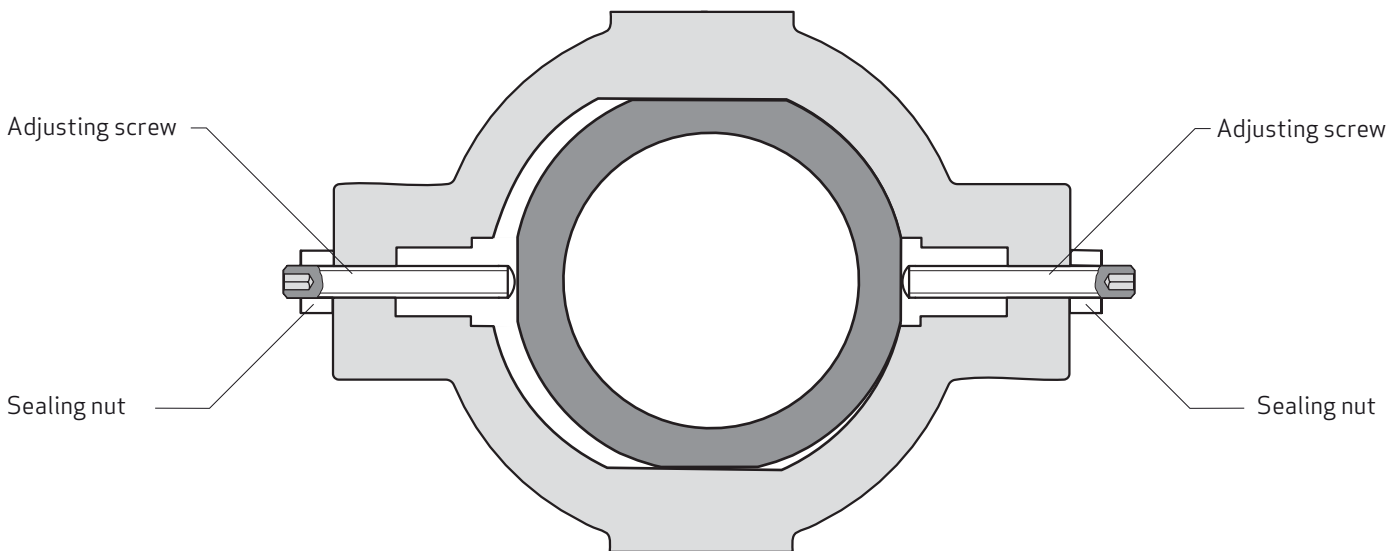

V [cm³/rev] [(cu.in/rev)]	19 (1.16)	32 (1.95)	45 (2.75)	63/80 (3.84/4.88)	100 (6.10)	140 (8.54)
ΔV for 1 mm (0.039 in) adjusting spindle travel (pitch 1.5 mm/rev (0.059 in/rev))	3.6 (0.22)	5.6 (0.34)	6.5 (0.40)	8.9 (0.54)	11.3 (0.69)	11.5 (0.70)

Important

When adjusting for the required delivery, ensure that the stroke ring remains held between the two adjusting spindles. When delivered, the pump is set as standard to V_{max} .

RADIAL PISTON PUMPS RKP-II FOR LOW-FLAMMABILITY FLUIDS

APPENDIX A – COMPENSATOR OPTIONS

5. SERVO CONTROL, C1

Actuated manually or mechanically by means of a lever. The pump displacement is controlled by the position of the lever.

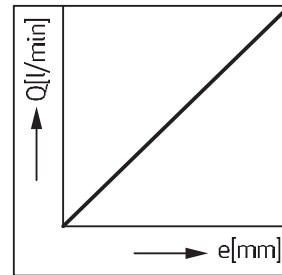
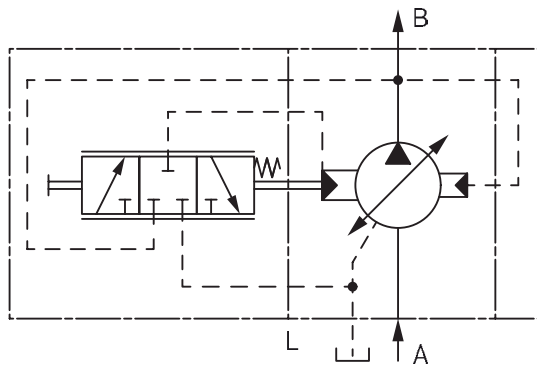

Eccentricity of stroke ring

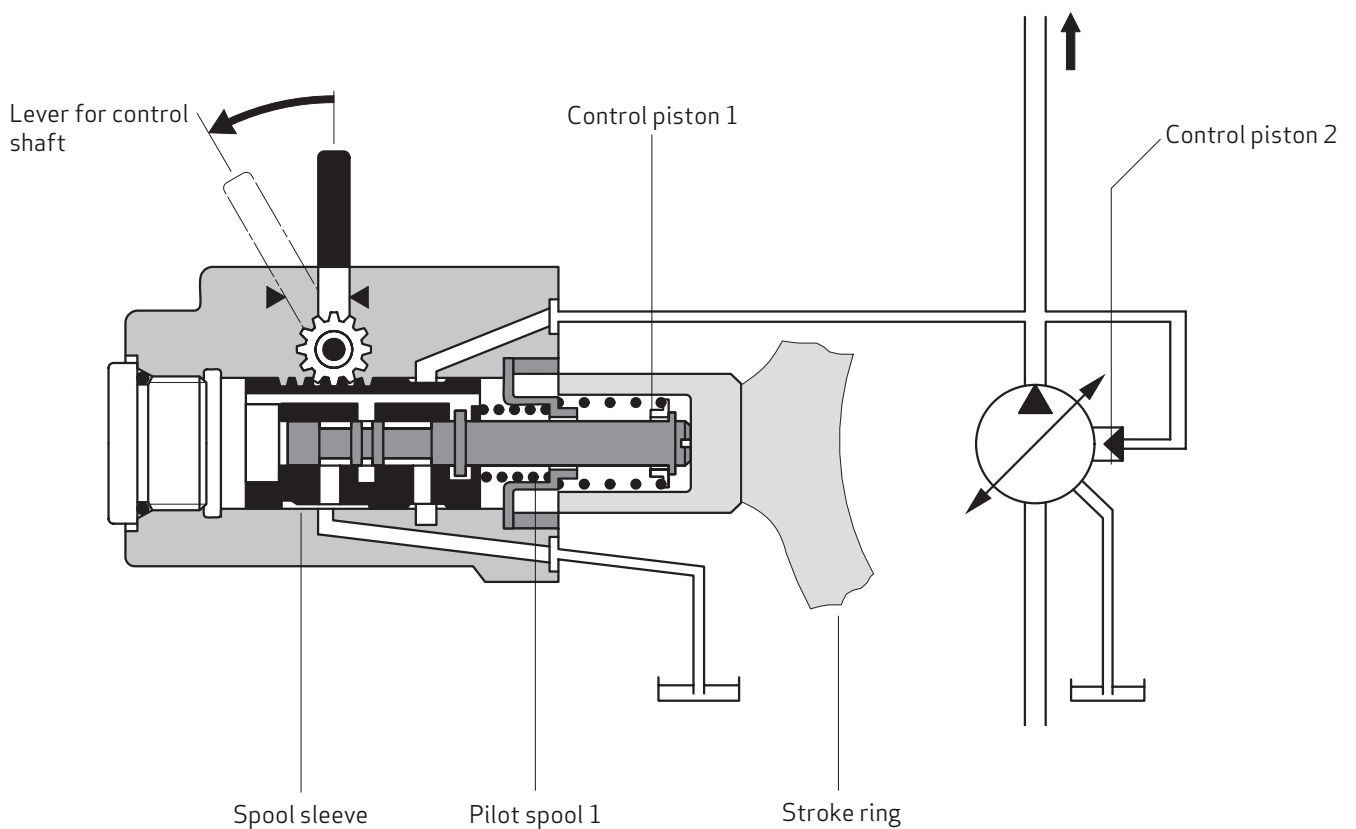

V [cm ³ /rev] ([cu.in/rev])	Control torque		
	Neutral position	Final position	Maximum permissible
19 (1.16)	1.2 Nm (0.89 lbf ft)	1.7 Nm (1.25 lbf ft)	8 Nm (5.90 lbf ft)
32, 45 (1.95, 2.75)	1.2 Nm (0.89 lbf ft)	1.7 Nm (1.25 lbf ft)	8 Nm (5.90 lbf ft)
63, 80 (3.84, 4.88)	1.6 Nm (1.18 lbf ft)	2.4 Nm (1.77 lbf ft)	8 Nm (5.90 lbf ft)
100 (6.10)	1.6 Nm (1.18 lbf ft)	2.4 Nm (1.77 lbf ft)	8 Nm (5.90 lbf ft)

RADIAL PISTON PUMPS RKP-II FOR LOW-FLAMMABILITY FLUIDS

APPENDIX A – COMPENSATOR OPTIONS

6. ELECTRO-HYDRAULIC CONTROL WITH DIGITAL ON-BOARD ELECTRONICS, D1 TO D8

- Control p/Q: Analog 0 V to 10 V or 4 mA to 20 mA or via CAN bus
- Pressure compensator with 16 selectable parameter sets
- 2 pressure sensors may be connected
- Integrated horse power controller
- Master/slave mode
- Pressure range up to 350 bar (5,000 psi) constant pressure

For a detailed description and further applications, see Supplementary Catalog RKP with digital control (RKP-D)

RKP WITH DIGITAL CONTROL (RKP-D)

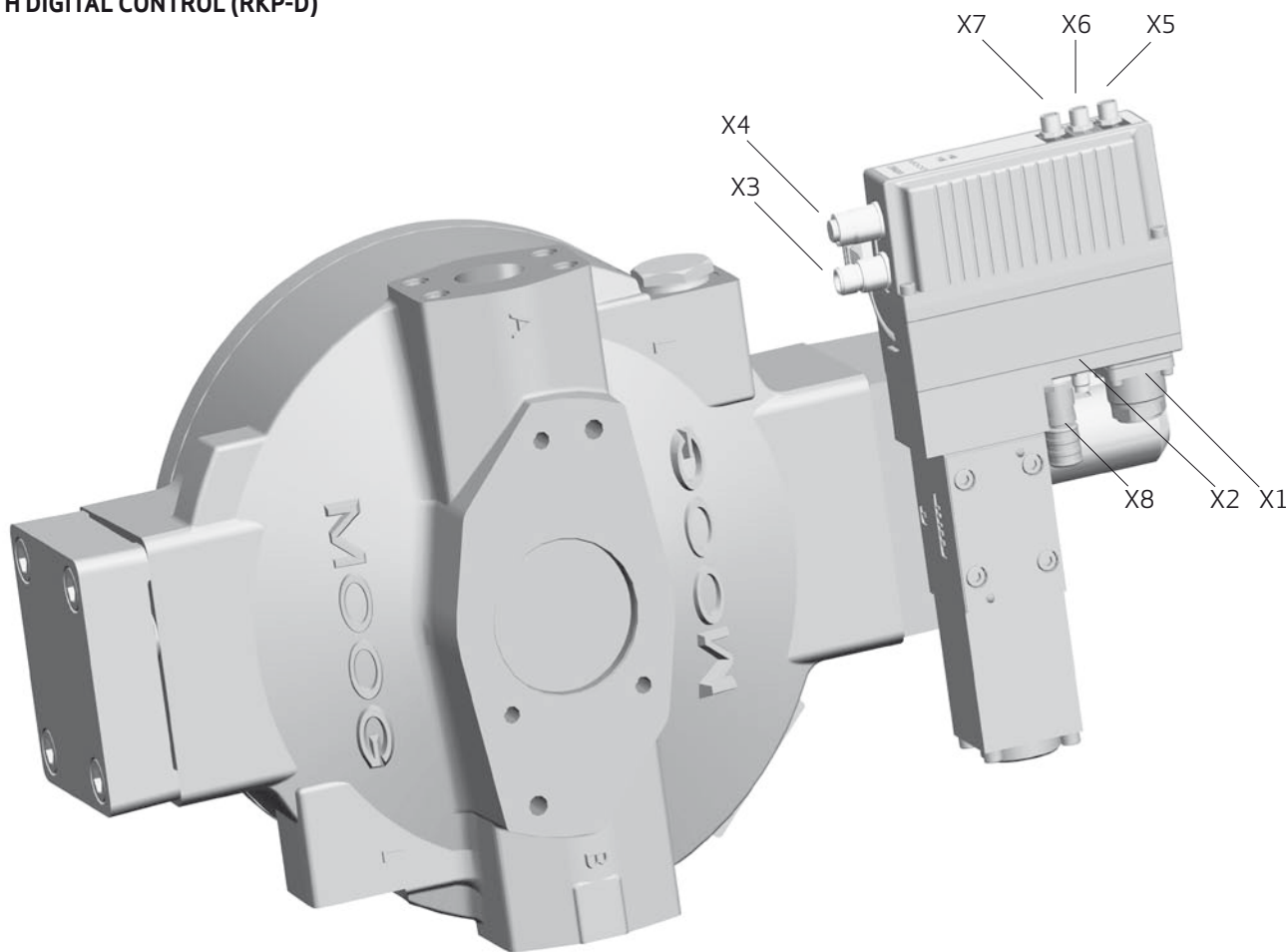

No.	Description	Type
X1	Main connector	11+PE 12-pole pin contact
X2	Local CAN (optional) for master/slave mode	M8 x 1 3-pole pin contact
X3	CAN-In	M12x1 5-pole pin contact
X4	CAN-Out	M12x1 5-pole socket contact
X5	Pressure sensor 2	M8 x 1 4-pole socket contact
X6	Pressure sensor 1	M8 x 1 4-pole socket contact
X7	Analog selection of parameter sets	M8 x 1 4-pole socket contact
X8	LVDT	M12x1 5-pole socket contact

Protection class for valve and LVDT: IP67 (with connected and locked receptacles respectively)

RADIAL PISTON PUMPS RKP-II FOR LOW-FLAMMABILITY FLUIDS

APPENDIX A – COMPENSATOR OPTIONS

ELECTRO-HYDRAULIC CONTROL WITH DIGITAL ON-BOARD ELECTRONICS, D1 TO D8

INTERNAL PRESSURE SUPPLY, D1

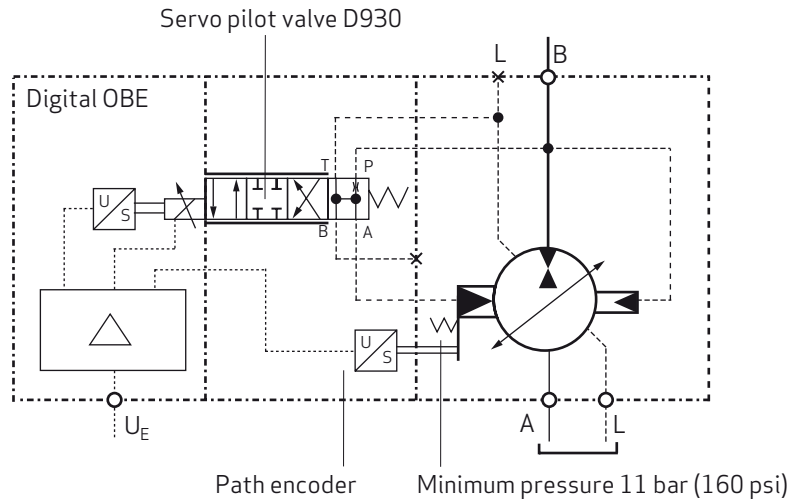

EXTERNAL PRESSURE SUPPLY, D2

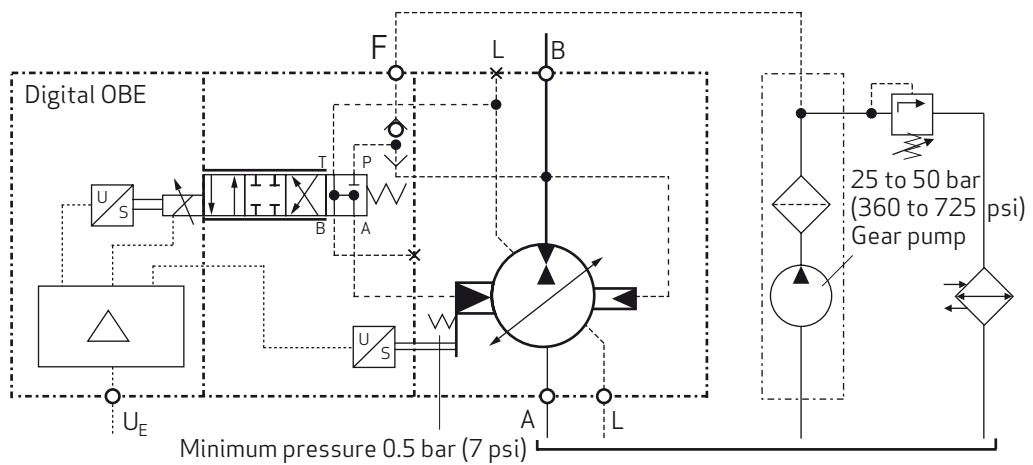

For more information on electro-hydraulically adjustable pumps, see catalog "RKP with digital control" (RKP-D).

RADIAL PISTON PUMPS RKP-II FOR LOW-FLAMMABILITY FLUIDS

APPENDIX B – TECHNICAL DRAWINGS HOUSINGS RKP-II 19 - 100

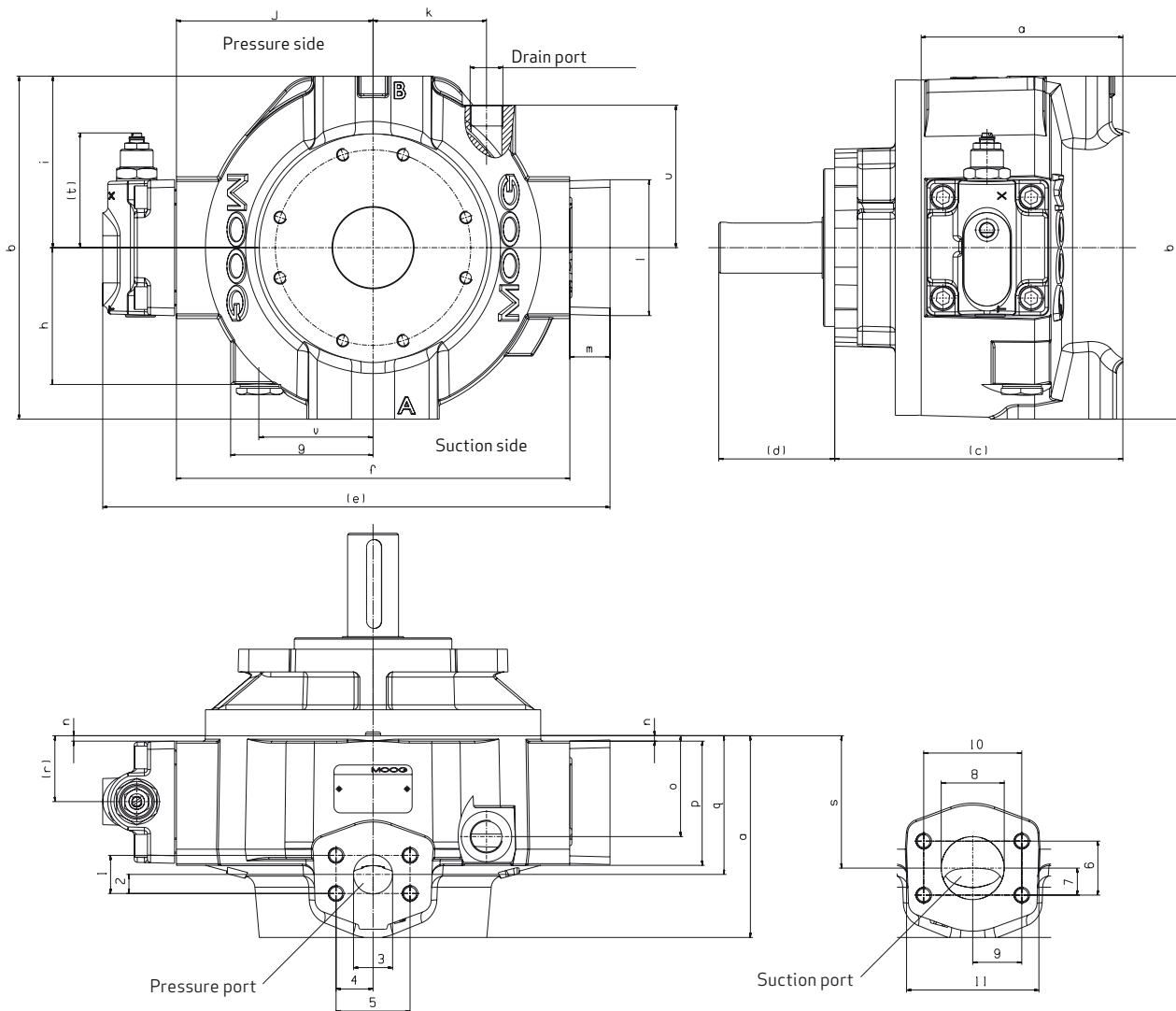

Caution
Illustration shows arrangement for clockwise rotation. For counterclockwise rotation the compensator is mounted on the opposite side. Change of rotation not possible.

MULTIPLE ARRANGEMENT EXAMPLE RKP 63 + 32

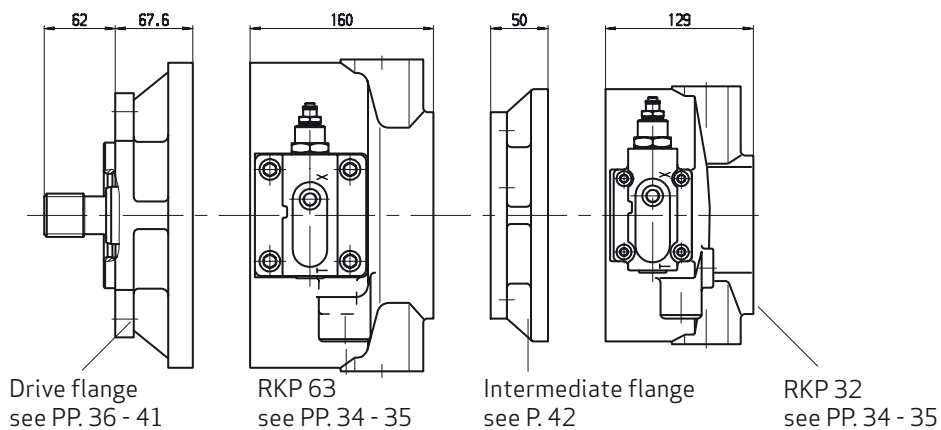

RADIAL PISTON PUMPS RKP-II FOR LOW-FLAMMABILITY FLUIDS

APPENDIX B – TECHNICAL DRAWINGS HOUSINGS RKP-II 19 - 140

		RKP 19		RKP 32/45		RKP 63/80/100		RKP 140
Length [mm] ([in])	A	104.00 (4.100)		129.00 (5.080)		160.00 (6.300)		173.50 (6.830)
Height [mm] ([in])	B	181.00 (7.130)		225.00 (8.860)		272.00 (10.710)		320.00 (12.600)
Width [mm] ([in])	(C)	163.10 (6.420)		103.00 (4.060)		228.60 (9.000)		-
	(D)	46.10 (1.820)		78.00 (3.070)		92.00 (3.630)		-
	(E)	290.50 (11.440)		319.30 (12.570)		402.50 (15.850)		483.20 (19.020)
	F	212.00 (8.350)		241.00 (9.490)		312.10 (12.280)		398.40 (15.690)
	G	78.00 (3.070)		97.00 (3.820)		113.00 (4.450)		130.00 (5.120)
	H	83.00 (3.270)		87.00 (3.430)		108.00 (4.250)		130.00 (5.120)
	I	90.50 (3.560)		112.50 (4.430)		136.00 (5.350)		160.00 (6.300)
	J	106.00 (4.170)		120.50 (4.740)		156.00 (6.140)		199.20 (8.840)
	K	56.00 (2.200)		84.00 (3.310)		90.00 (3.540)		-
Drain port		M18 x 1.5 to 13 deep (M0.71 x 0.06 to 0.51)		M22 x 1.5 to 14 deep (M0.89 x 0.06 to 0.55)		M26 x 1.5 to 16 deep (M1.02 x 0.06 to 0.63)		see flange
[mm] ([in])	L	80.00 (3.150)		81.40 (3.210)		107.70 (4.240)		109.40 (4.310)
	(M)	26.00 (1.020)		26.00 (1.020)		32.00 (1.260) (51.7 to D2, D3, D6)		34.80 (1.370)
	N	1.00 (0.040)		7.50 (0.300)		4.30 (0.170)		5.00 (0.200)
	O	55.00 (2.170)		66.00 (2.600)		80.00 (3.150)		-
	P	70.00 (2.760)		75.50 (2.970)		98.50 (3.880)		114.00 (4.500)
	Q	67.00 (2.640)		88.00 (3.470)		110.00 (4.330)		118.00 (4.650)
	(R)	35.00 (1.380)		41.20 (1.620)		52.25 (2.060)		-
	S	67.00 (2.640)		85.00 (3.350)		105.00 (4.130)		118.00 (4.650)
	(T)	max. 103.00 (4.060)		max. 103.00 (4.060)		max. 98.00 (3.500)		-
	U	83.00 (3.270)		87.00 (3.430)		113.00 (4.450)		130.00 (5.120)
	V	56.00 (2.200)		78.00 (3.070)		90.00 (3.540)		-
	Pressure port [mm] ([in])		SAE 3/4" 3,000 PSI	SAE 3/4" 6,000 PSI	SAE 1" 3,000 PSI	SAE 1" 6,000 PSI	SAE 1 1/4" 3,000 PSI	SAE 1 1/4" 6,000 PSI
1		22.20 (0.870)	23.90 (0.940)	26.20 (1.030)	27.80 (1.940)	30.16 (1.190)	31.70 (1.250)	36.50 (1.440)
2		11.10 (0.440)	11.95 (0.470)	13.10 (0.520)	13.90 (0.550)	15.08 (0.590)	15.85 (0.620)	18.25 (0.720)
3		19.00 (0.750)	19.00 (0.750)	25.00 (0.980)	25.00 (0.980)	26.00 (1.020)	31.00 (1.220)	38.00 (1.500)
4		23.81 (0.940)	25.40 (1.000)	26.20 (1.030)	28.60 (1.130)	29.37 (1.160)	33.34 (1.310)	39.65 (1.560)
5		47.60 (1.870)	50.80 (2.000)	52.40 (2.060)	57.20 (2.250)	58.74 (2.310)	66.68 (2.630)	79.30 (3.120)
12		M10 16 deep (0.63)	M10 16 deep (0.63)	M10 16 deep (0.63)	M12 21 deep (0.83)	M12 21 deep (0.83)	M14 24 deep (0.94)	M16 25.5 deep (1.00)
Suction port [mm] ([in])		SAE 3/4" 3,000 PSI	SAE 3/4" 6,000 PSI	SAE 1 1/2" 3,000 PSI		SAE 2" 3,000 PSI		SAE 2 1/2" 3,000 PSI
	6	22.20 (0.870)	23.90 (0.870)	35.70 (1.410)		42.80 (1.690)		50.80 (2.000)
	7	11.10 (0.440)	11.95 (0.440)	17.85 (0.700)		21.40 (0.840)		25.40 (1.000)
	8	19.00 (0.750)	19.00 (0.750)	38.00 (1.500)		50.00 (1.970)		62.00 (2.440)
	9	23.81 (0.940)	25.40 (1.000)	34.95 (1.380)		38.90 (1.530)		44.45 (1.750)
	10	47.60 (1.870)	50.80 (2.000)	69.90 (2.750)		77.80 (3.060)		88.90 (3.500)
	11	71.00 (2.800)	71.00 (2.800)	98.00 (3.860)		105.00 (4.130)		117.50 (4.630)
	13	M10 16 deep (0.63)	M10 16 deep (0.63)	M12 24 deep (0.95)		M12 22.5 deep (0.89)		M12 22 deep (0.87)

() = as shown with flange A7 and with compensator, F, H, J, R and without maximum flow limiting.

RADIAL PISTON PUMPS RKP-II FOR LOW-FLAMMABILITY FLUIDS

APPENDIX B – TECHNICAL DRAWINGS DRIVE FLANGES RKP-II 19 - 100

FLANGES, A1

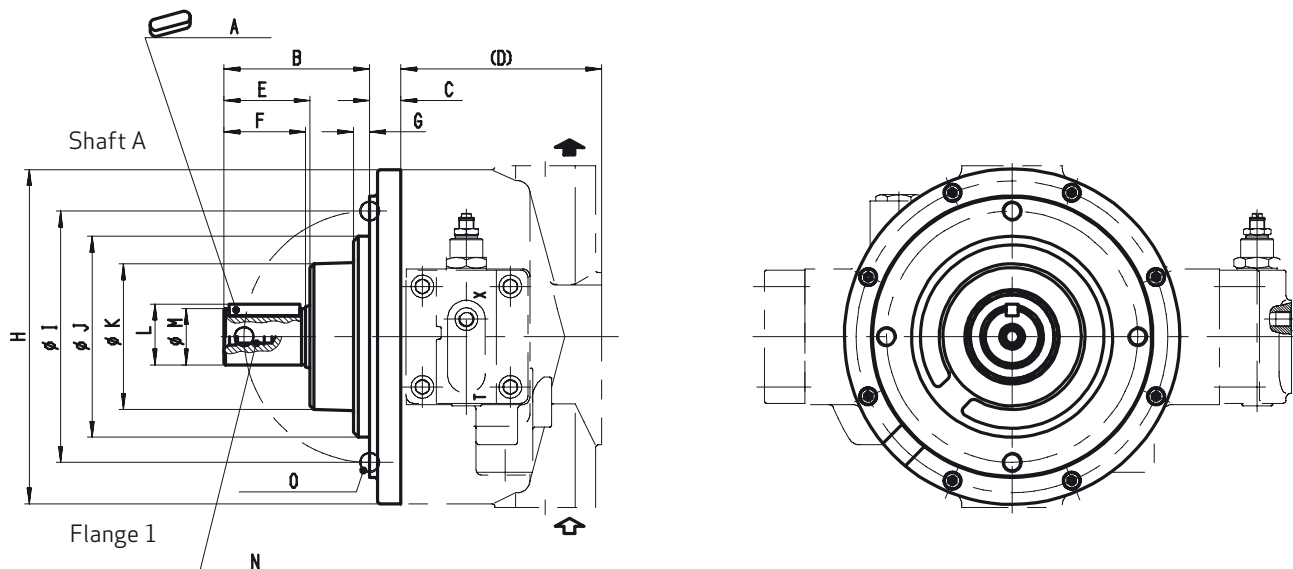

Straight key according to ISO 2491

Metric round flange

	RKP 19 [mm] ([in])		RKP 32/45 [mm] ([in])		RKP 63/80/100 [mm] ([in])	
A	A 8 x 7 x 32 ISO 2491		A 10 x 8 x 45 ISO 2491		A 14 x 9 x 56 ISO 2491	
B	70.70	(2.780)	94.50	(3.720)	116.00	(4.570)
C	17.10	(0.670)	18.10	(0.710)	24.70	(0.970)
(D)	104.00	(4.090)	129.00	(5.080)	160.00	(6.300)
E	42.90	(1.690)	57.50	(2.260)	68.50	(2.700)
F	41.20	(1.620)	55.00	(2.170)	65.00	(2.560)
G	11.40	(0.450)	11.00	(0.430)	13.00	(0.510)
H	177.00	(6.970)	220.00	(8.660)	267.00	(10.510)
I	125.00 ±0.15 (4.920 ±0.006)		160.00 ±0.15 (6.300 ±0.006)		200.00 ±0.15 (7.870 ±0.006)	
J	100.00 -0.036/-0.090 (3.940 -0.001/-0.003)		125.00 -0.043/-0.106 (4.920 -0.001/-0.004)		160.00 -0.043/-0.106 (6.300 -0.001/-0.004)	
K	79.00	(3.110)	101.00	(4.000)	116.00	(4.570)
L	30.75	(1.210)	37.85	(1.490)	48.40	(1.910)
M	28.00 -0.013 (1.100 -0.001)		35.00 -0.016 (1.380 -0.001)		45.00 -0.016 (1.770 -0.001)	
N	M10 22 deep	(0.87)	M10 22 deep	(0.87)	M12 32 deep	(1.26)
O	M10 15 deep	(0.59)	M12 16 deep	(0.63)	M16 23 deep	(0.91)

RADIAL PISTON PUMPS RKP-II FOR LOW-FLAMMABILITY FLUIDS

APPENDIX B – TECHNICAL DRAWINGS DRIVE FLANGES RKP-II 19 - 100

FLANGES, B1

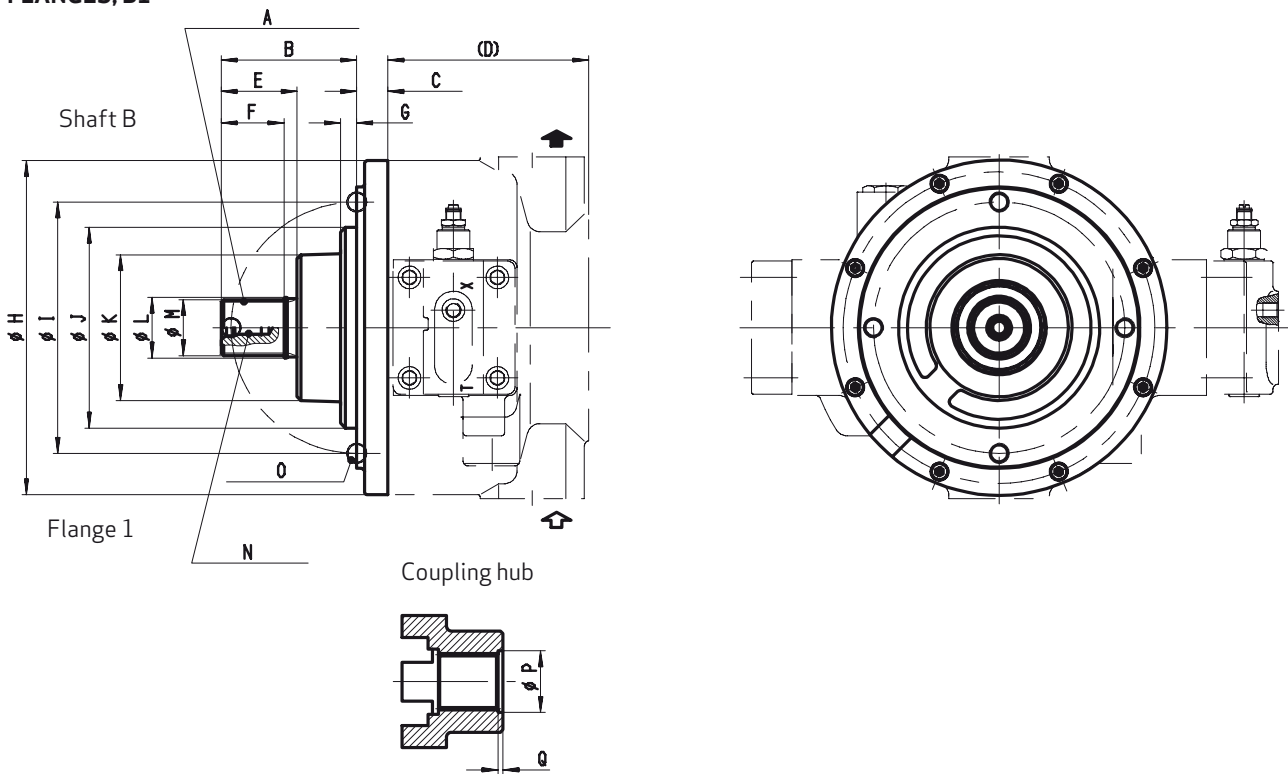

Involute spline according to DIN 5482 (for B1)
 (obligatory with multiple arrangement of RKP and SAE-B)
 Metric round flange

	RKP 19 [mm] ([in])	RKP 32/45 [mm] ([in])	RKP 63/80/100 [mm] ([in])
A	DIN 5482 B 28 x 25 e9	DIN 5482 B 35 x 31 e9	DIN 5482 B 45 x 41 e9
B	72.60 (2.860)	95.50 (3.760)	107.90 (4.250)
C	17.10 (0.670)	18.10 (0.710)	24.70 (0.970)
(D)	104.00 (4.090)	129.00 (5.080)	160.00 (6.300)
E	44.80 (1.760)	58.50 (2.300)	60.40 (2.380)
F	30.00 (1.180)	40.00 (1.570)	50.00 (1.970)
G	11.40 (0.450)	11.00 (0.430)	13.00 (0.510)
H	177.00 (6.970)	220.00 (8.660)	267.00 (10.510)
I	125.00 ±0.15 (4.920 ±0.006)	160.00 ±0.15 (6.300 ±0.006)	200.00 ±0.15 (7.870 ±0.006)
J	100.00 -0.036/-0.090 (3.940 -0.001/-0.003)	125.00 -0.043/-0.106 (4.920 -0.001/-0.004)	160.00 -0.043/-0.106 (6.300 -0.001/-0.004)
K	79.00 (3.110)	101.00 (3.980)	116.00 (5.570)
L	30.80 ±0.25 (1.210 ±0.010)	38.50 ±0.25 (1.520 ±0.010)	48.45 ±0.25 (1.910 ±0.010)
M	27.50 -0.130 (1.080 -0.001)	34.44 -0.160 (1.360 -0.001)	44.50 -0.160 (1.750 -0.001)
N	M10 22 deep (0.87)	M10 22 deep (0.87)	M12 32 deep (1.26)
O	M10 15 deep (0.59)	M12 15 deep (0.59)	M16 23 deep (0.91)
P	31.30 +0.20 (1.230 +0.008)	39.00 +0.20 (1.340 +0.008)	49.00 +0.20 (1.930 +0.008)
Q	4.00 (0.160)	4.00 (0.160)	4.00 (0.160)

RADIAL PISTON PUMPS RKP-II FOR LOW-FLAMMABILITY FLUIDS

APPENDIX B – TECHNICAL DRAWINGS DRIVE FLANGES RKP-II 19 - 100

FLANGES, A7

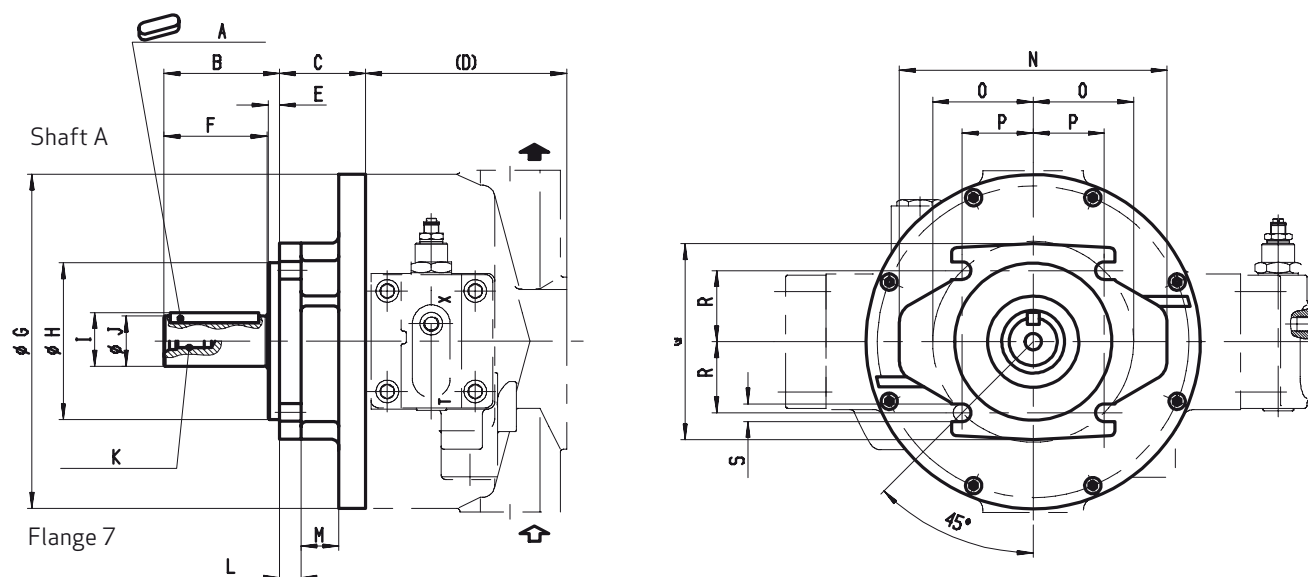

Straight key according to ISO 2491
ISO flange according to ISO 3019/2
(metric dimensions)

HFA pumps have an unplugged inspection hole in the drive flange which must always be located at the bottom.
If necessary, the mounting flange must be rotated.

	RKP 19 [mm] ([in])	RKP 32/45 [mm] ([in])	RKP 63/80/100 [mm] ([in])
A	A 8 x 7 x 36 ISO 2491	A 10 x 8 x 50 ISO 2491	A 12 x 8 x 70 ISO 2491
B	52.00 (2.050)	68.00 (2.680)	92.00 (3.620)
C	58.10 (2.870)	64.10 (2.520)	68.60 (2.700)
(D)	104.00 (4.090)	129.00 (5.080)	160.00 (6.300)
E	9.00 (0.350)	9.00 (0.350)	9.00 (0.350)
F	42.00 (1.650)	58.00 (2.280)	82.00 (3.230)
G	177.00 (6.970)	220.00 (8.660)	267.00 (10.510)
H	100.00 -0.054 (3.940 -0.002)	125.00 -0.063 (4.920 -0.002)	125.00 -0.063 (4.920 -0.002)
I	27.75 (1.090)	34.75 (1.370)	42.75 (1.680)
J	25.00 +0.009/-0.004 (0.980 -0.001/-0.001)	32.00 +0.018/+0.002 (1.260 -0.001/-0.001)	40.00 +0.018/+0.002 (1.570 -0.001/-0.001)
K	M8 22 deep (0.87)	M10 22 deep (0.87)	M12 32 deep (1.26)
L	11.20 (0.440)	17.20 (0.680)	17.20 (0.680)
M	30.00 (1.180)	30.00 (1.180)	30.00 (1.180)
N	174.00 (6.850)	213.00 (8.390)	213.00 (8.390)
O	62.50 (2.460)	80.00 (3.150)	80.00 (3.150)
P	44.20 (1.740)	56.58 (2.230)	56.58 (2.230)
Q	126.00 (4.960)	156.00 (6.140)	156.00 (6.140)
R	44.20 (1.740)	56.58 (2.230)	56.58 (2.230)
S	11.00 (0.430)	14.00 (0.550)	14.00 (0.550)

RADIAL PISTON PUMPS RKP-II FOR LOW-FLAMMABILITY FLUIDS

APPENDIX B – TECHNICAL DRAWINGS DRIVE FLANGES RKP-II 19 - 100

DRIVE FLANGES B7

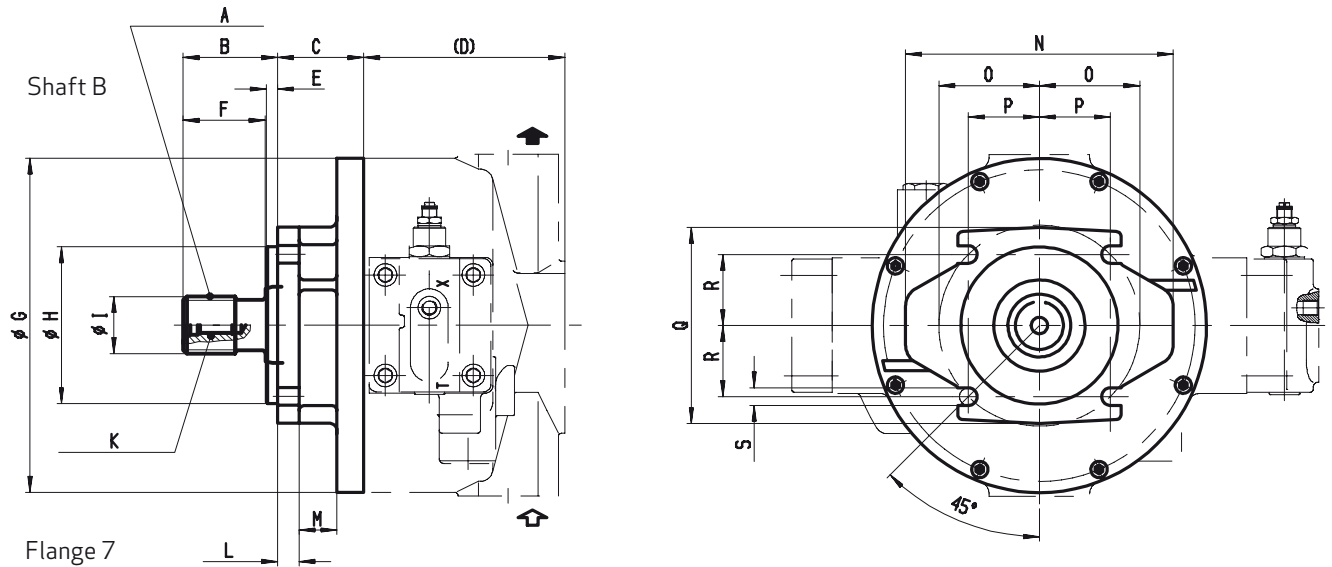

Involute spline according to DIN 5480
 (obligatory with multiple arrangement of RKP and SAE-B)
 ISO flange according to ISO 3019/2
 (metric dimensions)

	RKP 19 [mm] ([in])	RKP 32/45 [mm] ([in])	RKP 63/80/100 [mm] ([in])
A	W25 x 1.25 x 30 x 18 x 8f	W32 x 2 x 30 x 14 x 8f	W40 x 2 x 30 x 18 x 8f
B	42.00 (1.650)	46.00 (1.810)	54.00 (2.130)
C	58.10 (2.870)	64.10 (2.520)	68.60 (2.700)
(D)	104.00 (4.090)	129.00 (5.080)	160.00 (6.300)
E	9.00 (0.350)	9.00 (0.350)	9.00 (0.350)
F	32.00 (1.260)	36.00 (1.420)	44.00 (1.730)
G	177.00 (6.970)	220.00 (8.660)	267.00 (10.510)
H	100.00 -0.054 (3.940 -0.002)	125.00 -0.063 (4.920 -0.002)	125.00 -0.063 (4.920 -0.002)
I	25.00 (0.980)	32.00 (1.260)	40.00 (1.570)
K	M8 22 deep (0.87)	M10 22 deep (0.87)	M12 32 deep (1.26)
L	11.20 (0.440)	17.20 (0.680)	17.20 (0.680)
M	30.00 (1.180)	30.00 (1.180)	30.00 (1.180)
N	174.00 (6.850)	213.00 (8.390)	213.00 (8.390)
O	62.50 (2.460)	80.00 (3.150)	80.00 (3.150)
P	44.20 (1.740)	56.58 (2.230)	56.58 (2.230)
Q	126.00 (4.960)	156.00 (6.140)	156.00 (6.140)
R	44.20 (1.740)	56.58 (2.230)	56.58 (2.230)
S	11.00 (0.430)	14.00 (0.550)	14.00 (0.550)

RADIAL PISTON PUMPS RKP-II FOR LOW-FLAMMABILITY FLUIDS

APPENDIX B – TECHNICAL DRAWINGS DRIVE FLANGES RKP-II 19 - 100

DRIVE FLANGES C3

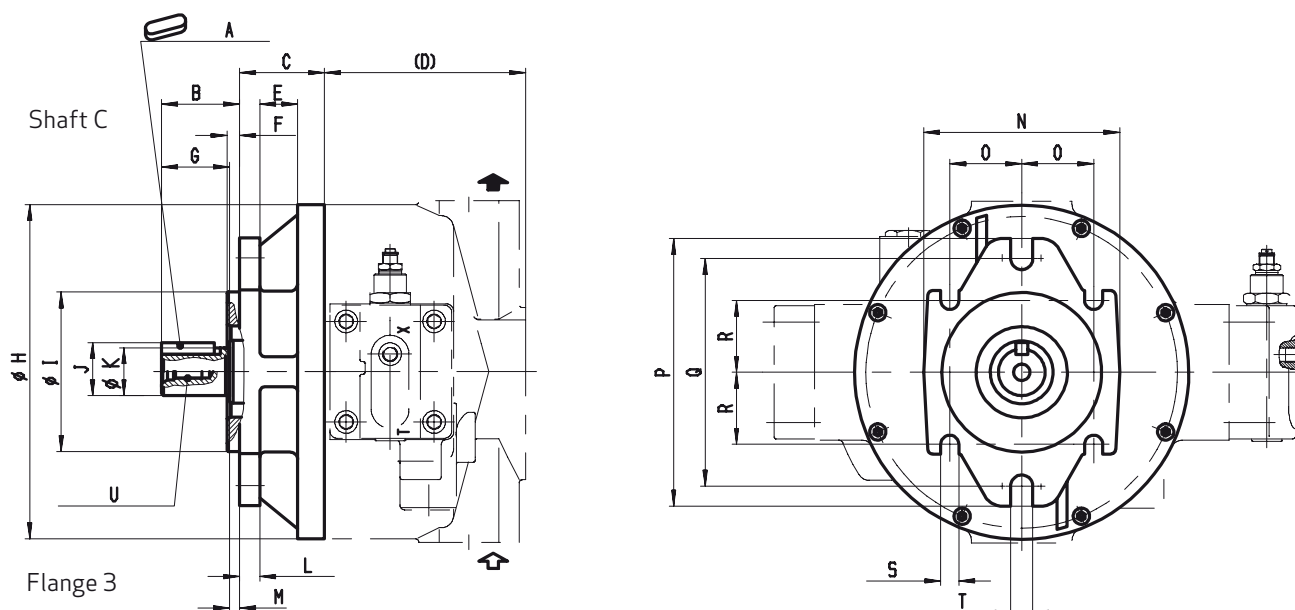

Key to SAE Standard
SAE flange according to ISO 3019/1
(imperial dimensions)

	RKP 19 [mm] ([in])		RKP 32/45 [mm] ([in])		RKP 63/80/100 [mm] ([in])	
A	6.35 x 6.35 x 25.4		7.94 x 7.94 x 32.0		9.53 x 9.53 x 42.0	
B	46.10	(1.820)	57.50	(2.260)	62.00	(2.440)
C	59.10	(2.330)	63.10	(2.480)	67.60	(2.660)
(D)	104.00	(4.090)	129.00	(5.080)	160.00	(6.300)
E	30.00	(1.810)	30.00	(1.810)	30.00	(1.810)
F	8.00	(0.310)	10.00	(0.390)	10.00	(0.390)
G	36.70	(1.440)	46.00	(1.810)	54.00	(2.130)
H	177.00	(6.970)	220.00	(8.660)	267.00	(10.510)
I	101.60-0.05	(4.000-0.002)	127.00-0.05	(5.000-0.002)	127.00-0.05	(5.000-0.002)
J	28.09	(1.110)	35.21	(1.390)	42.27	(1.660)
K	25.40-0.05	(1.000-0.002)	31.75-0.05	(1.250-0.002)	38.10-0.05	(1.500-0.002)
L	12.20	(0.480)	16.20	(0.640)	16.20	(0.640)
M	9.40	(0.370)	11.50	(0.450)	8.00	(0.310)
N	126.00	(4.960)	156.00	(6.140)	156.00	(6.140)
O	45.00	(1.770)	57.25	(2.250)	57.25	(2.250)
P	174.00	(6.850)	213.00	(8.390)	213.00	(8.390)
Q	146.00	(5.750)	181.00	(7.130)	181.00	(7.130)
R	45.00	(1.770)	57.25	(2.250)	57.25	(2.250)
S	14.40	(0.570)	14.40	(0.570)	14.40	(0.570)
T	14.40	(0.570)	17.60	(0.690)	17.60	(0.690)
U	3/8"-16UNC-2B 22 deep	(0.87)	3/8"-16UNC-2B 22 deep	(0.87)	7/16"-14UNC-2B 32 deep	(1.26)

RADIAL PISTON PUMPS RKP-II FOR LOW-FLAMMABILITY FLUIDS

APPENDIX B – TECHNICAL DRAWINGS DRIVE FLANGES RKP-II 19 - 100

DRIVE FLANGES D3

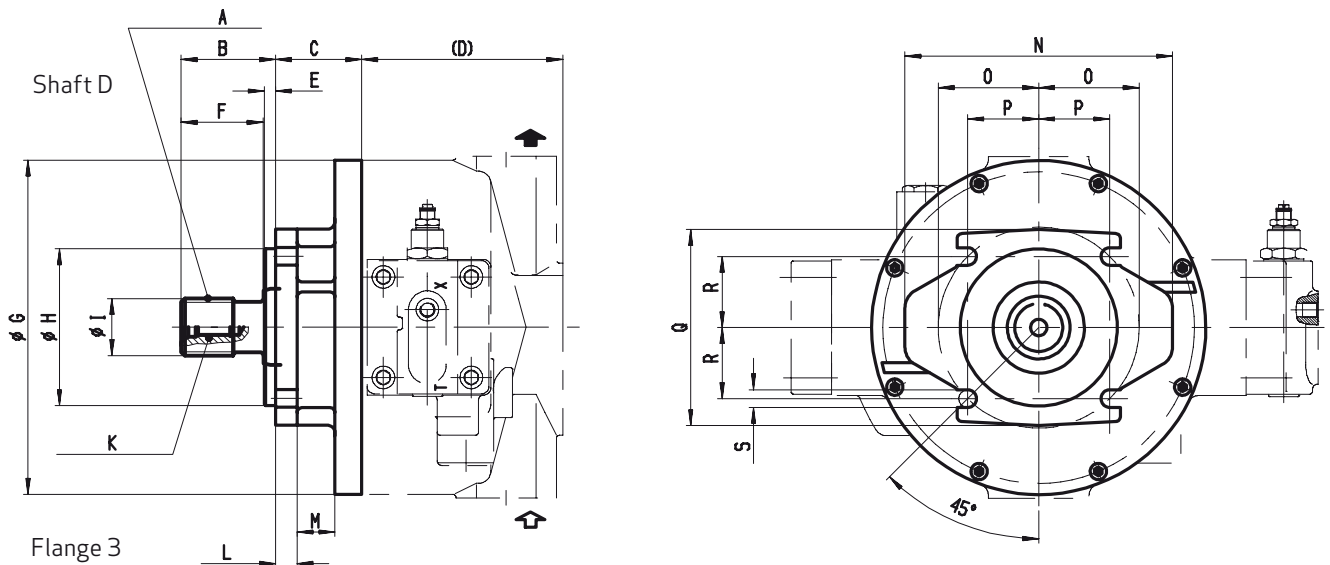

Involute spline according to SAE 744 C
 (obligatory with multiple arrangement of RKP and SAE-B)
 SAE flange according to ISO 3019/1
 (imperial dimensions)

	RKP 19 [mm] ([in])		RKP 32/45 [mm] ([in])		RKP 63/80/100 [mm] ([in])	
A	ANSI B92.1-1970 Class 5 30PA. 15T, 16/32DP Flat root side fit		ANSI B92.1-1970 Class 5 30PA. 14T, 12/24DP Flat root side fit		ANSI B92.1-1970 Class 5 30PA. 17T, 12/24DP Flat root side fit	
B	46.00	(1.810)	56.00	(2.210)	62.00	(2.440)
C	59.10	(2.330)	63.10	(2.480)	67.60	(2.660)
(D)	104.00	(4.090)	129.00	(5.080)	160.00	(6.300)
E	30.00	(1.810)	30.00	(1.810)	30.00	(1.810)
F	8.00	(0.310)	10.00	(0.390)	10.00	(0.390)
G	38.00	(1.500)	48.00	(1.890)	54.00	(2.130)
H	23.00	(0.910)	29.00	(1.140)	34.00	(1.340)
I	177.00	(6.970)	220.00	(8.660)	267.00	(10.510)
J	101.60	(4.000)	127.00	85.00	127.00	(5.000)
K	25.20	(0.990)	31.50	(1.240)	37.70	(1.480)
L	12.20	(0.480)	16.20	(0.640)	16.20	(0.640)
M	8.00	(0.310)	8.00	(0.310)	8.00	(0.310)
N	126.00	(4.960)	156.00	(6.140)	156.00	(6.140)
O	45.00	(1.770)	57.25	(2.250)	57.25	(2.250)
P	174.00	(6.850)	213.00	(8.390)	213.00	(8.390)
Q	146.00	(5.750)	181.00	(7.130)	181.00	(7.130)
R	45.00	(1.770)	57.25	(2.250)	57.25	(2.250)
S	14.40	(0.570)	14.40	(0.570)	14.40	(0.570)
T	14.40	(0.570)	17.60	(0.690)	17.60	(0.690)
U	3/8"-16UNC-2B 22 deep	(0.87)	3/8"-16UNC-2B 22 deep	(0.87)	7/16"-14UNC-2B 32 deep	(1.26)

RADIAL PISTON PUMPS RKP-II FOR LOW-FLAMMABILITY FLUIDS

APPENDIX B – TECHNICAL DRAWINGS INTERMEDIATE FLANGES RKP-II 19 - 100

INTERMEDIATE FLANGE RKP-RKP, XX

RKP 19/32/45

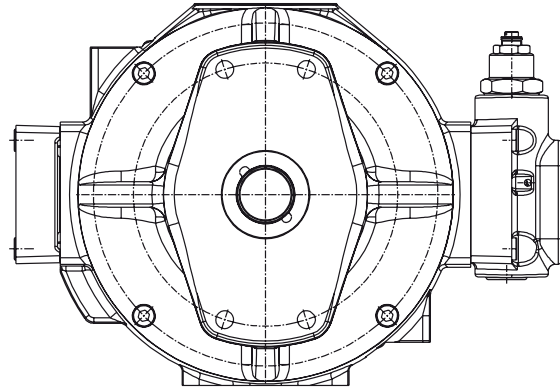
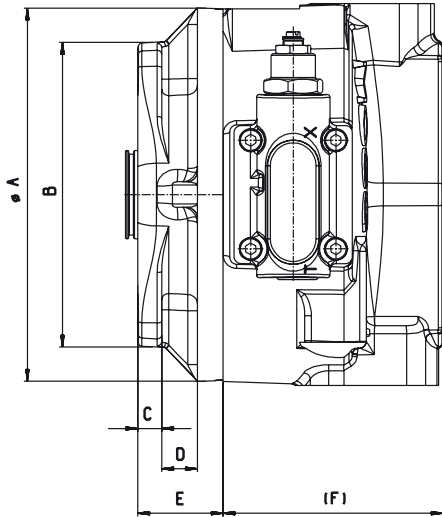

RKP 63/80/100

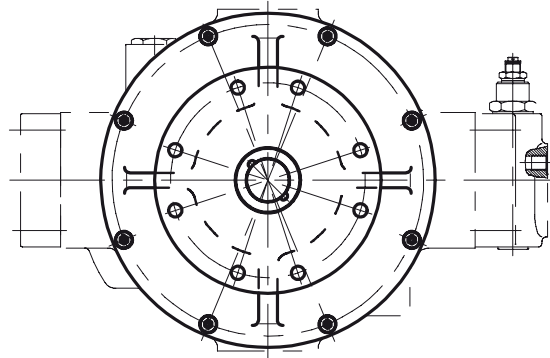
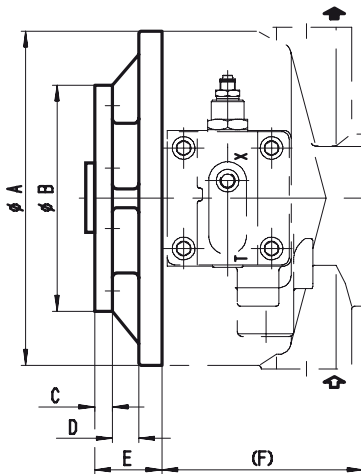

	RKP 19 [mm] ([in])	RKP 32/45 [mm] ([in])	RKP 63/80/100 [mm] ([in])
A	177.00 (6.970)	220.00 (8.660)	266.00 (10.470)
B	180.00 (7.090)	180.00 (7.090)	180.00 (7.090)
C	14.00 (0.550)	14.00 (0.550)	14.00 (0.550)
D	23.50 (0.930)	21.00 (0.830)	21.00 (0.830)
E	50.00 (1.970)	50.00 (1.970)	53.50 (2.110)
(F)	104.00 (4.090)	129.00 (5.080)	160.00 (6.300)

RADIAL PISTON PUMPS RKP-II FOR LOW-FLAMMABILITY FLUIDS

APPENDIX B – TECHNICAL DRAWINGS COMPENSATORS RKP-II 19 - 100

ADJUSTABLE PRESSURE COMPENSATOR, F1, F2
 HYDRAULICALLY ACTUATED PRESSURE COMPENSATOR, H1
 COMBINED PRESSURE AND FLOW COMPENSATOR, J1
 PRESSURE AND FLOW COMPENSATOR WITH P-T LAND, R1

RKP 19/32/45

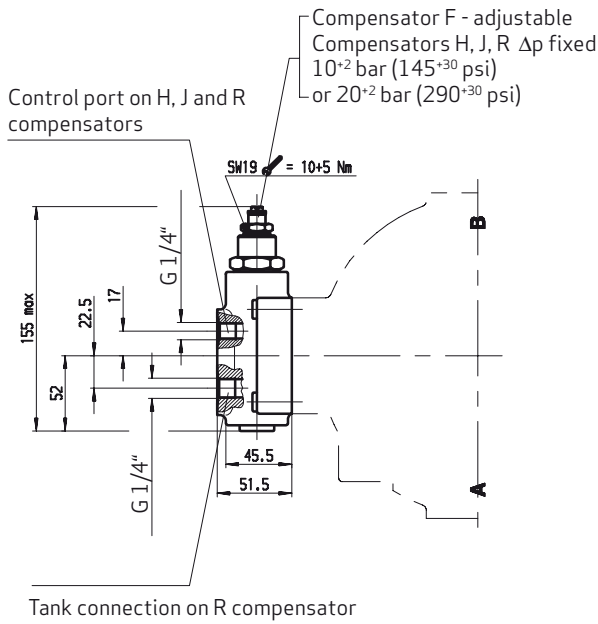

RKP 63/80/100

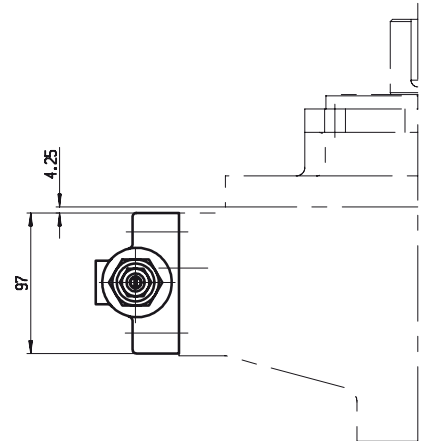
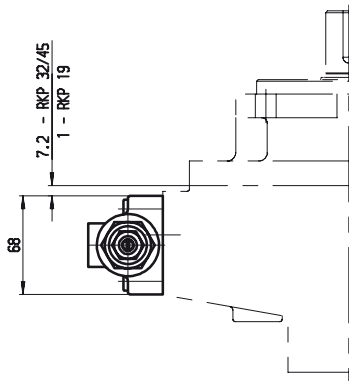
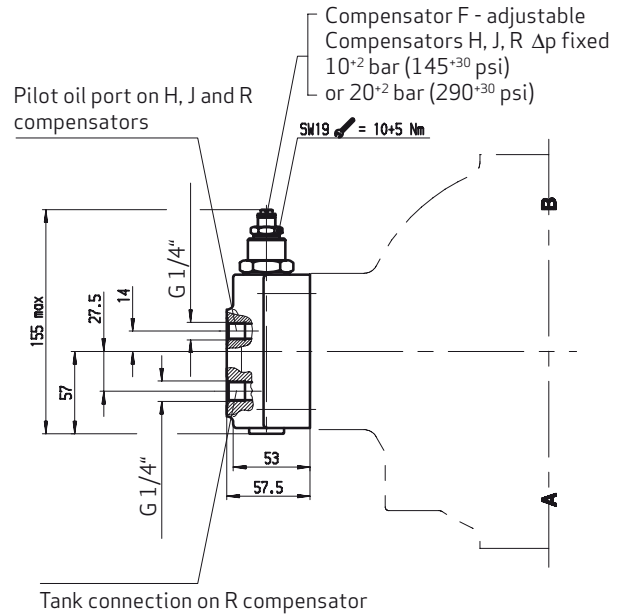

RADIAL PISTON PUMPS RKP-II FOR LOW-FLAMMABILITY FLUIDS

APPENDIX B – ADJUSTMENT PILOT OIL LINE COMPENSATORS RKP-II 19 - 100

ADJUSTABLE PRESSURE COMPENSATOR, F1, F2

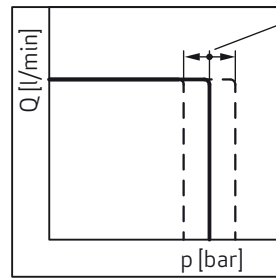
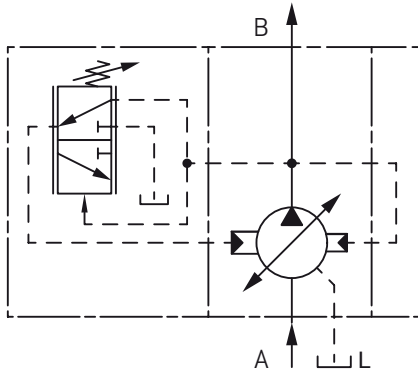

Screw adjustment

HYDRAULICALLY ACTUATED PRESSURE COMPENSATOR, H1

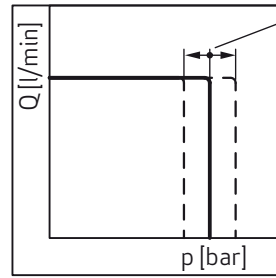
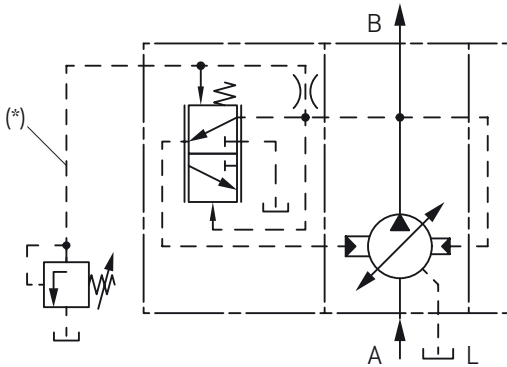

Screw adjustment

COMBINED PRESSURE AND FLOW COMPENSATOR, J1, J2

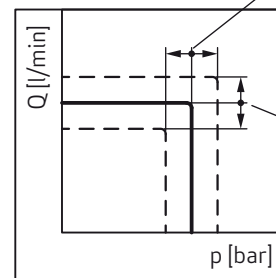
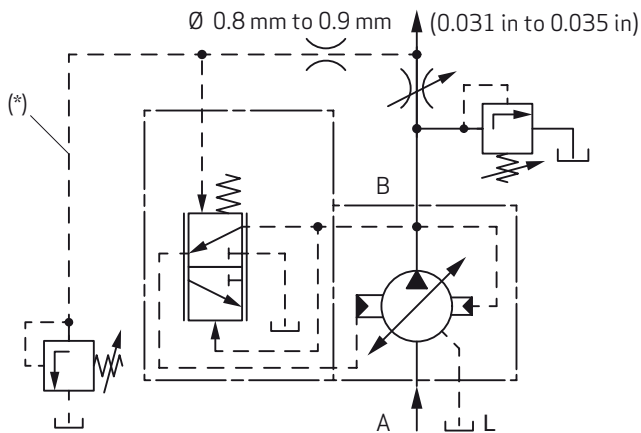

Screw adjustment

Set at metering throttle

When high dynamics are required for flow control, adjust orifice and control line accordingly.

* Hose recommendation for control line

RKP 19	DN 6
RKP 32, RKP 45	DN 8
RKP 63, RKP 80, RKP 100	DN 10
l = 800 mm (31.50 in)	

RADIAL PISTON PUMPS RKP-II FOR LOW-FLAMMABILITY FLUIDS

APPENDIX B – ADJUSTMENT PILOT OIL LINE COMPENSATORS RKP-II 19 - 100

COMBINED PRESSURE AND FLOW COMPENSATOR “LOAD SENSING” WITH P-T LAND, R1

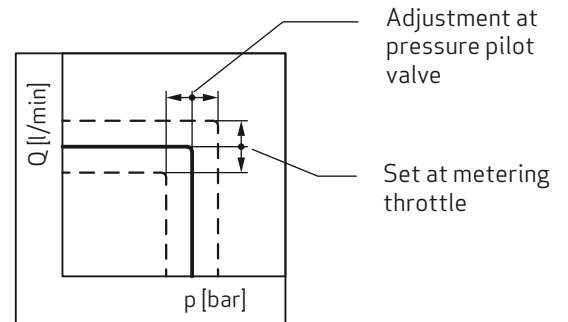
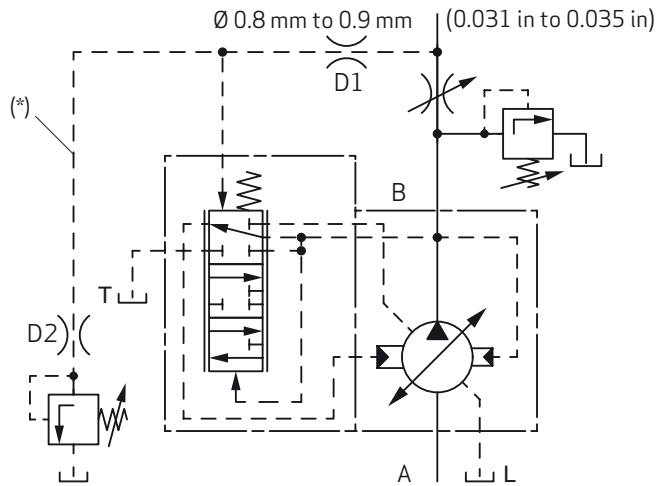

* Recommendation: Hose for pilot oil line

		D1 [mm] ([in])	D2 [mm] ([in])
RKP 19 to 45	DN 6	0.9 (0.035)	1.2 (0.047)
RKP 63 to 100	DN 8	0.9 (0.035)	1.2 (0.047)
I = 800 mm (31.50 in)			

Notes on multiple pump circuits

In the case of multiple pumps, which deliver into one circuit, the P-T control notch may only be activated for the compensator of the first pump by connecting the T-connection to the tank. The T-connection of the compensators of add-on pumps must be sealed off.

Caution!

The tank line of the compensator must not be combined with the drain line of the pump.

RADIAL PISTON PUMPS RKP-II FOR LOW-FLAMMABILITY FLUIDS

APPENDIX B – TECHNICAL DRAWINGS COMPENSATORS RKP-II 19 - 100

ADJUSTABLE PRESSURE COMPENSATOR, LOCKABLE WITH H KEY, G1, G2

RKP 19/32/45

RKP 63/80/100

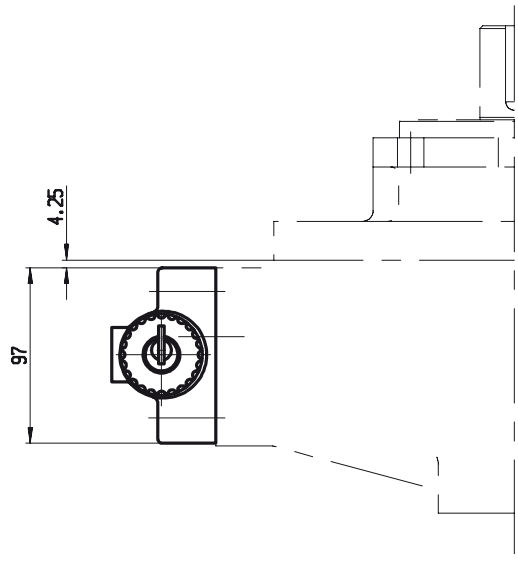
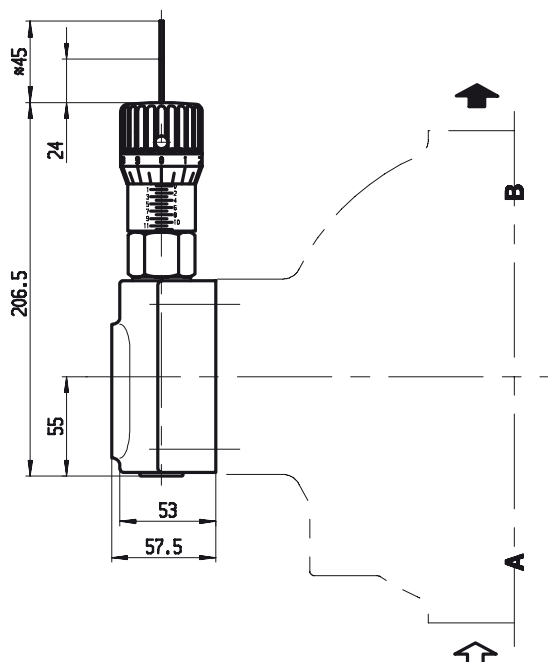
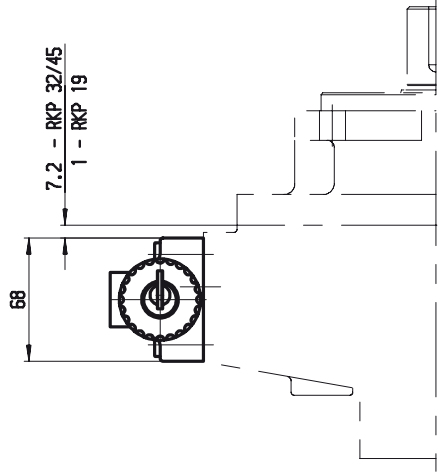
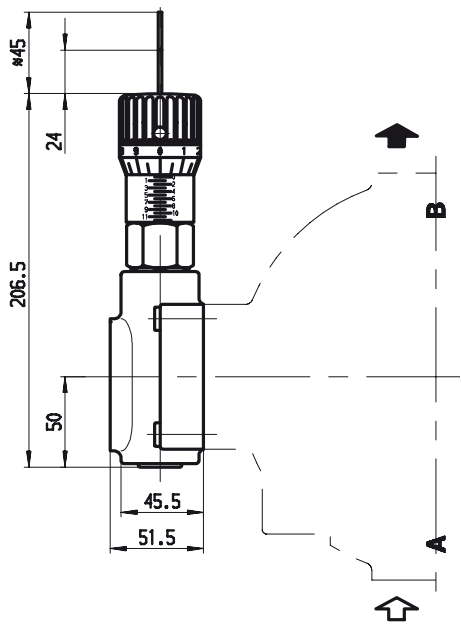

RADIAL PISTON PUMPS RKP-II FOR LOW-FLAMMABILITY FLUIDS

APPENDIX B – TECHNICAL DRAWINGS COMPENSATORS RKP-II 19 - 100

ELECTRO-HYDRAULIC CONTROL WITH DIGITAL ON-BOARD ELECTRONICS, D1 TO D8

RKP 19/32/45

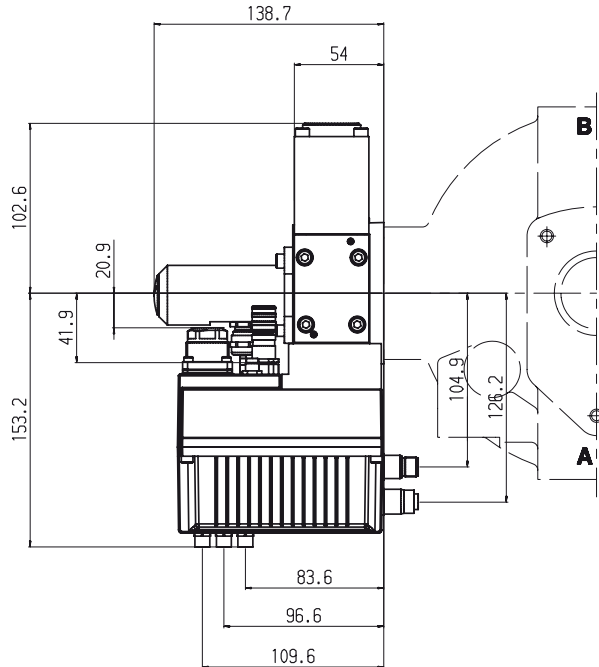

RKP 63/80/100

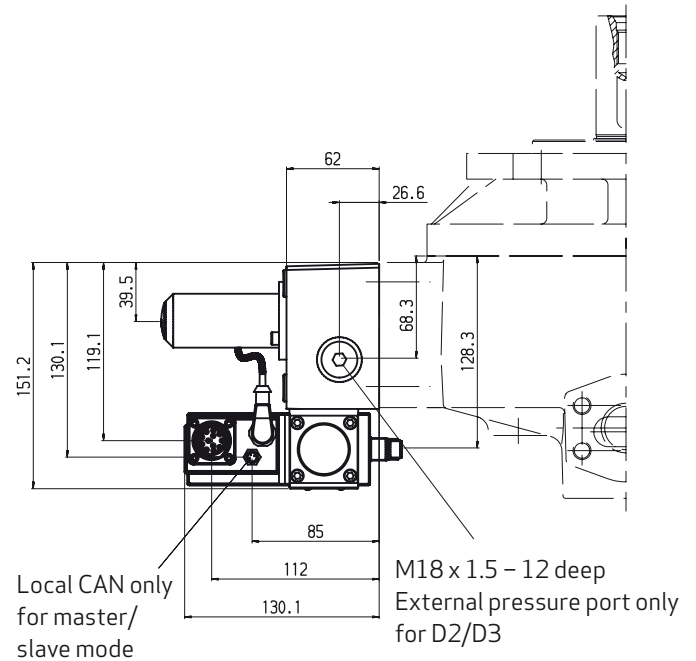
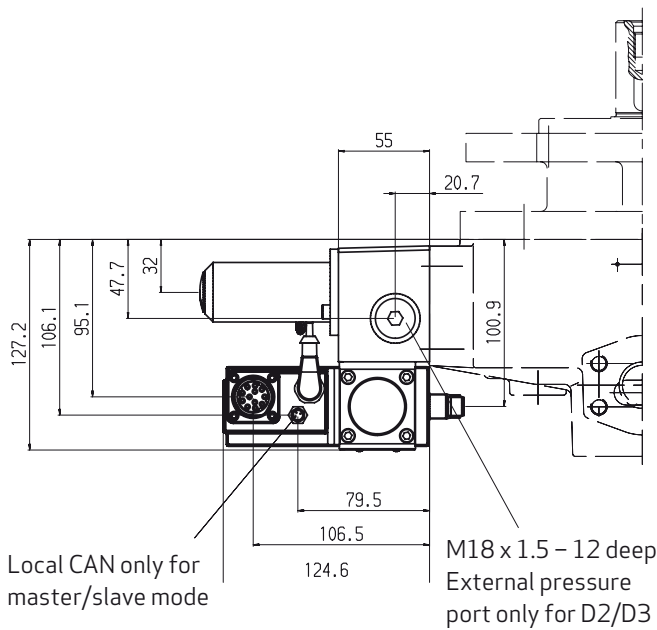
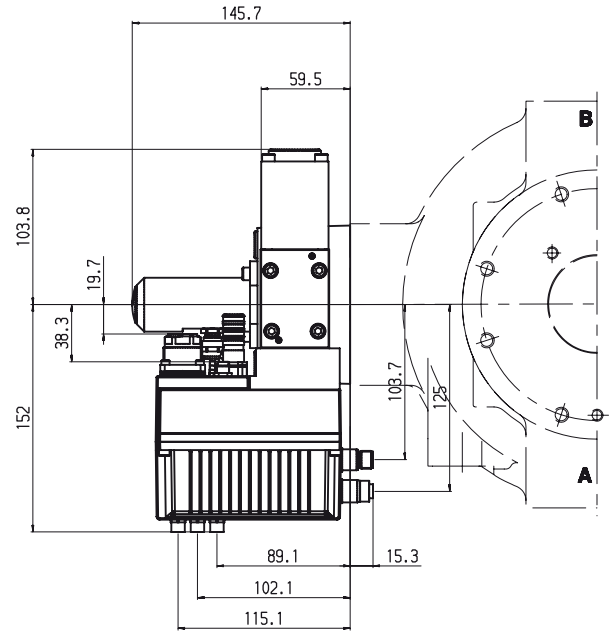

RADIAL PISTON PUMPS RKP-II FOR LOW-FLAMMABILITY FLUIDS

APPENDIX B – TECHNICAL DRAWINGS COMPENSATORS RKP-II 19 - 100

SERVO CONTROL C1

RKP 19/32/45

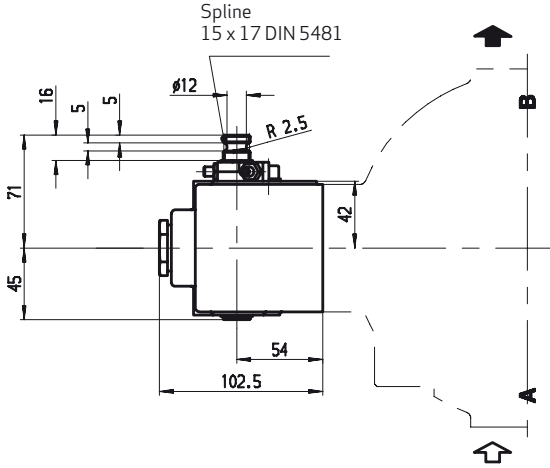

RKP 63/80/100

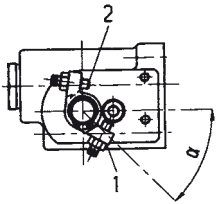
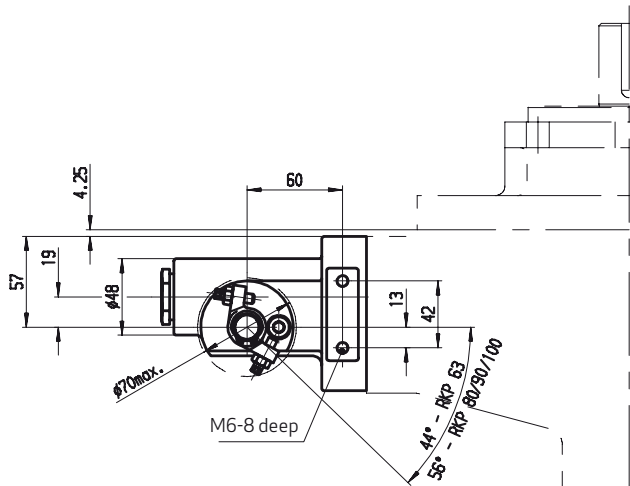
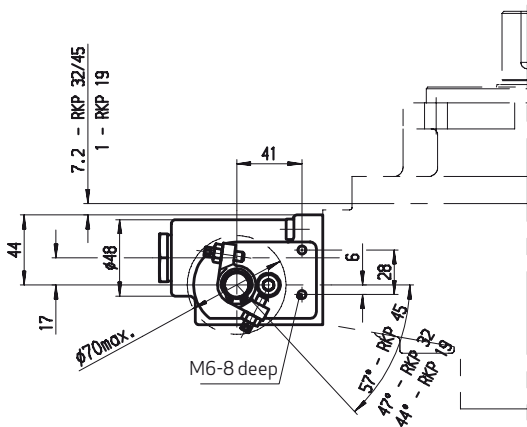
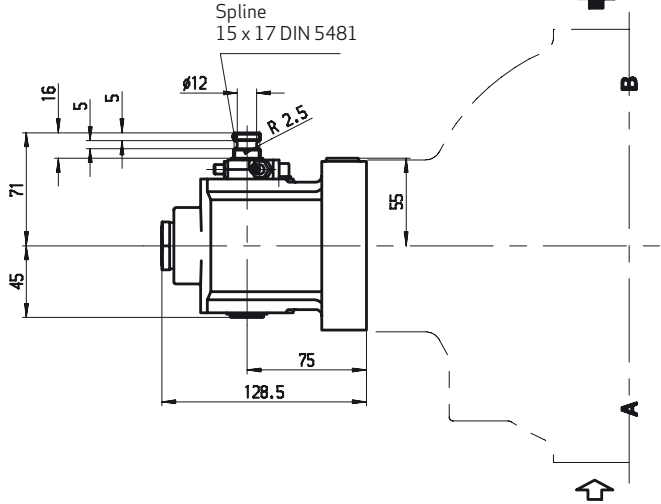

- 1 Zero stroke stop (set at factory)
- 2 End stop at $\pm V_{max}$ (set at factory)

	V [cm³/rev]	19	32	45	63	80	100
	([cu.in/rev])	(1.16)	(1.95)	(2.75)	(3.84)	(4.88)	(6.10)
	α [°]	44	47	57	44	56	56
Torque M [Nm] ([lbf ft])	Zero position	1.2 (0.89)			1.6 (1.18)		
	End position	1.6 (1.18)	1.7 (1.25)	2.4 (1.77)	2.6 (1.92)	2.6 (1.92)	
	Maximum	8 (5.90)					

RADIAL PISTON PUMPS RKP-II FOR LOW-FLAMMABILITY FLUIDS

APPENDIX B – TECHNICAL DRAWINGS COMPENSATORS RKP-II 19 - 100

MAXIMUM FLOW LIMITER Y

RKP 19/32/45

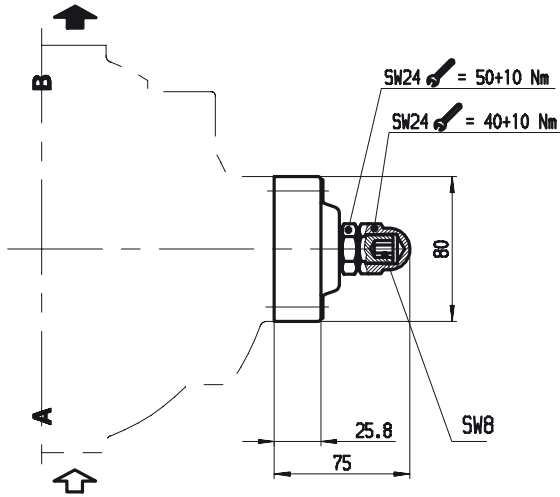

RKP 63/80/100

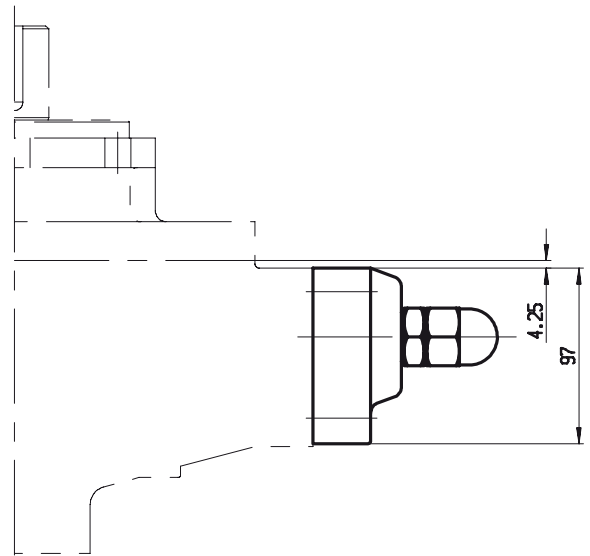
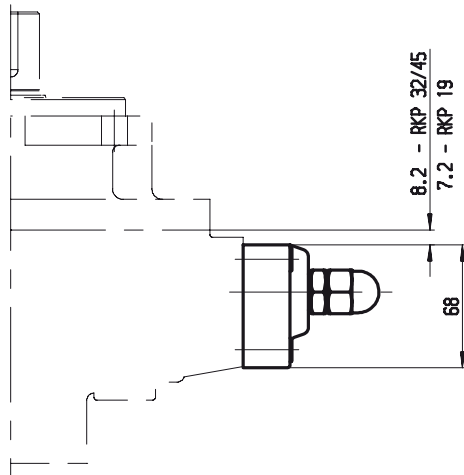
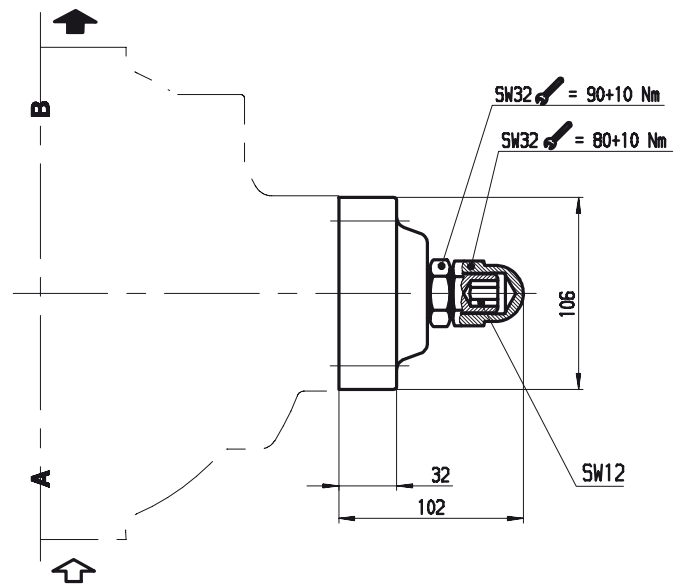

V [cm ³ /rev] ([cu.in/rev])	19 (1.16)	32 (1.95)	45 (2.75)	63/80 (3.48/4.88)	100 (6.10)
ΔV for 1 mm (0.039 in) travel of adjusting screw (pitch 1.5 mm/rev (0.059 in/rev))	3.6 (0.22)	5.6 (0.34)	6.5 (0.40)	8.9 (0.54)	11.3 (0.69)

RADIAL PISTON PUMPS RKP-II FOR LOW-FLAMMABILITY FLUIDS

APPENDIX B – TECHNICAL DRAWINGS COMPENSATORS RKP-II 19 - 100

MECHANICAL STROKE ADJUSTMENT B1

RKP 19-100

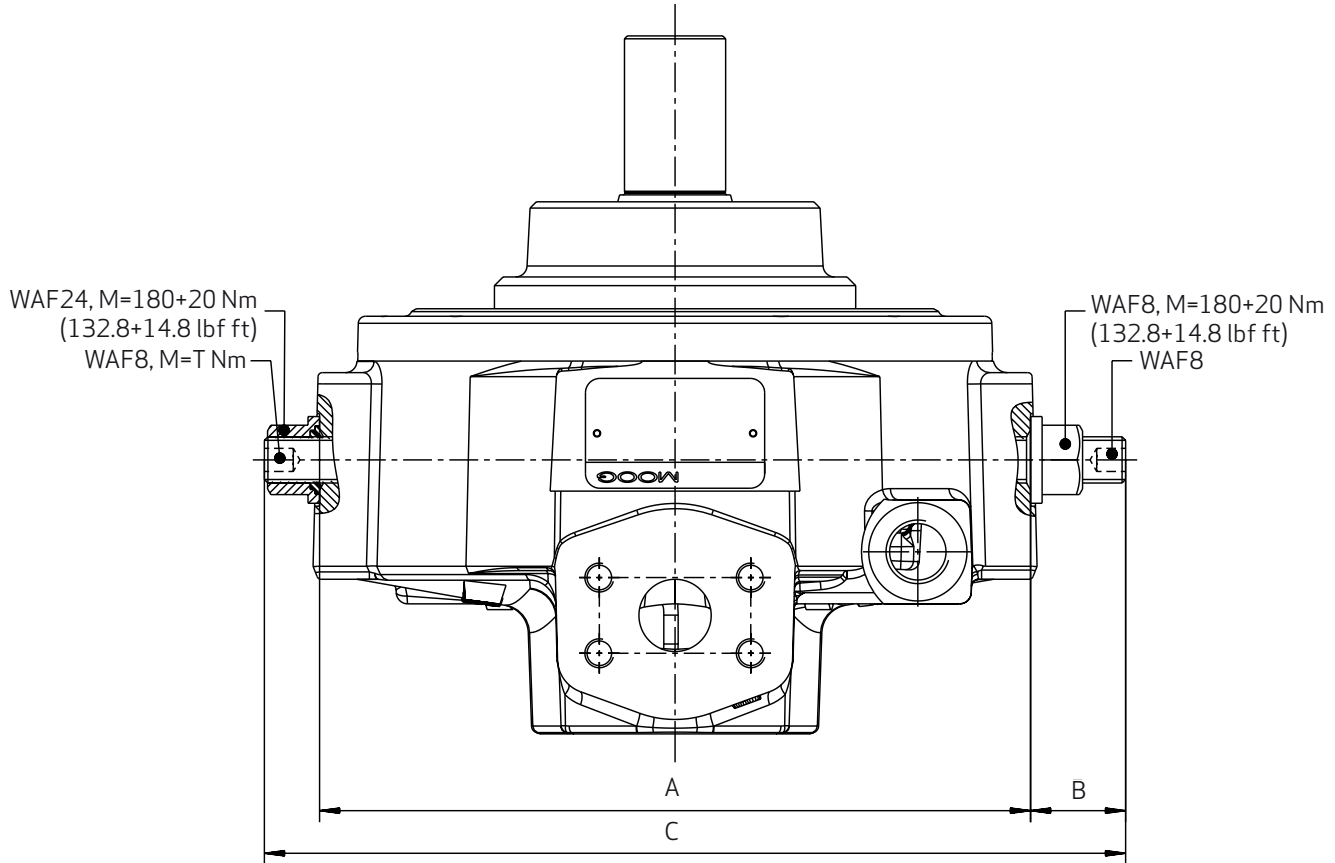

V [cm³/rev] ([cu.in/rev])	19 (1.16)	32 (1.95)	45 (2.75)	63 (3.84)	80 (4.88)	100 (6.10)
A [mm] ([in])	212 (8.35)	246 (9.69)	246 (9.69)	312 (12.28)	312 (12.28)	312 (12.28)
B [mm] ([in])	32.9 (1.30)	31.8 (1.25)	33.0 (1.30)	40.8 (1.61)	42.7 (1.68)	42.5 (1.67)
C [mm] ([in])	267 (10.51)	298 (11.73)	298 (11.73)	379 (14.92)	379 (14.92)	379 (14.92)
T [Nm] ([lbf ft])	15+5 (11.1+3.7)	15+5 (11.1+3.7)	15+5 (11.1+3.7)	26+4 (19.2+3.0)	26+4 (19.2+3.0)	26+4 (19.2+3.0)
ΔV for 1 mm (0.039 in) travel of adjusting screw (pitch 1.5 mm/rev (0.059 in/rev))	3.6 (0.22)	5.6 (0.34)	6.5 (0.40)	8.9 (0.54)	8.9 (0.54)	11.3 (0.69)

Important

When adjusting for the required delivery, ensure that the stroke ring remains held between the two adjusting screws.

When delivered, the pump is set to V_{max} .

RADIAL PISTON PUMPS RKP-II FOR LOW-FLAMMABILITY FLUIDS

APPENDIX B – TECHNICAL DRAWINGS HOUSING RKP-II 140

RKP 140 SHOWN WITH FLANGE A7 AND COMPENSATOR R1

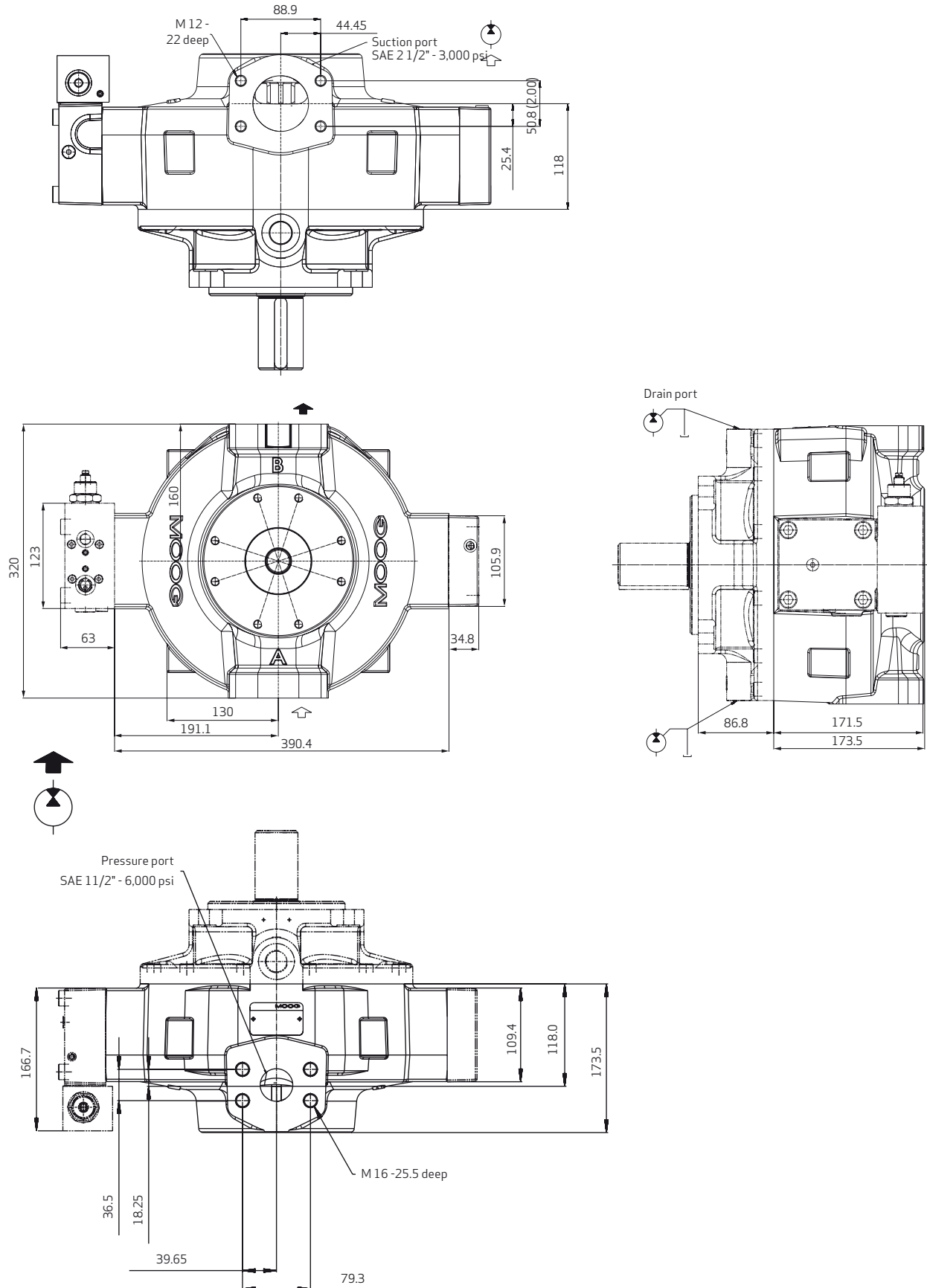

RADIAL PISTON PUMPS RKP-II FOR LOW-FLAMMABILITY FLUIDS

APPENDIX B – TECHNICAL DRAWINGS HOUSING RKP-II 140

DRIVE FLANGE A7

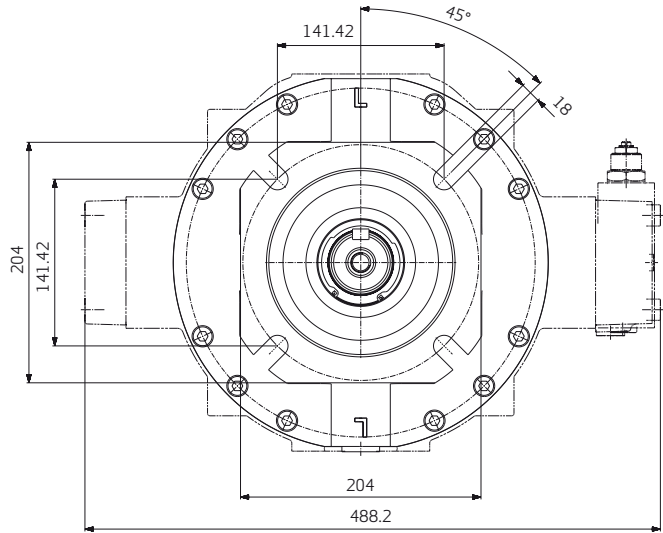
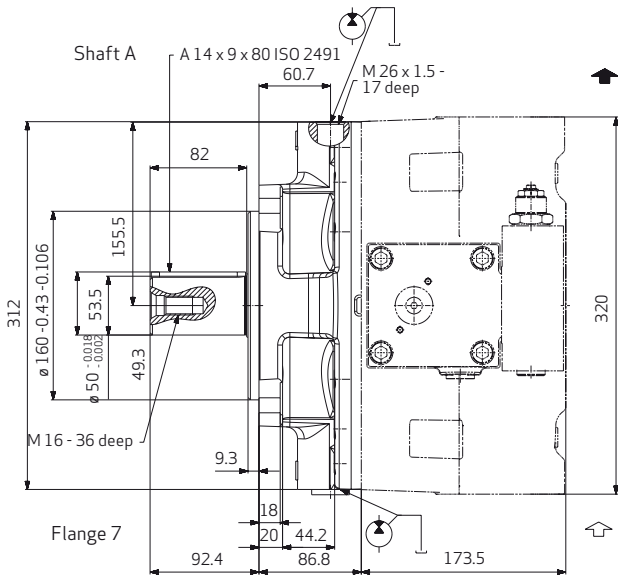

Straight key according to ISO 2491
 ISO mounting flange to DIN ISO 3019/2 (metric dimensions)

DRIVE FLANGES B7

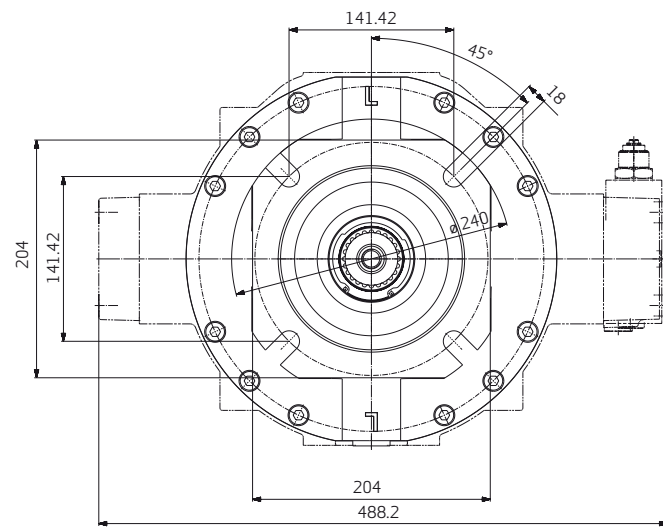
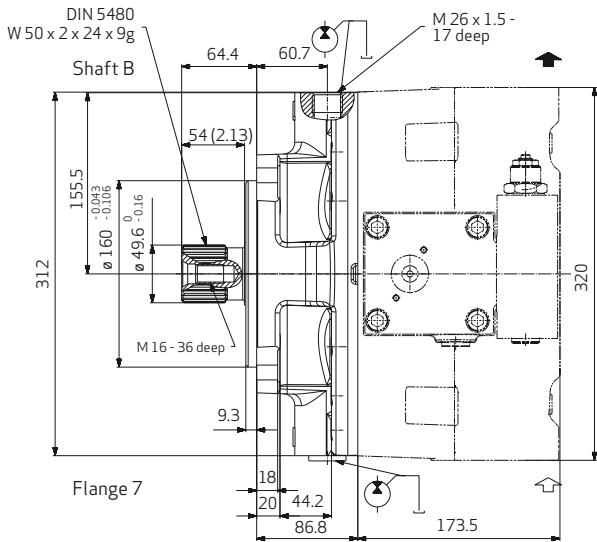

Involute spline according to DIN 5480 (for RKP mounting obligatory)
 ISO mounting flange to DIN ISO 3019/2 (metric dimensions)

RADIAL PISTON PUMPS RKP-II FOR LOW-FLAMMABILITY FLUIDS

APPENDIX B – TECHNICAL DRAWINGS DRIVE FLANGES RKP 140

Drive flange C3

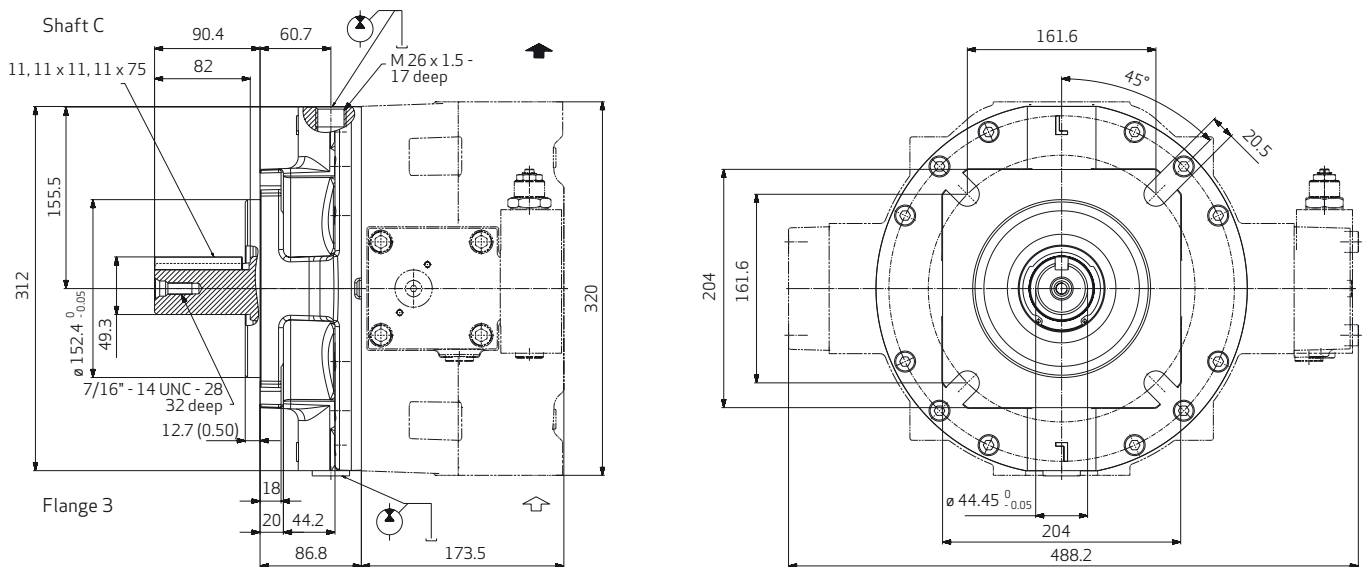

Key to SAE Standard
 SAE mounting flange to DIN ISO 3019/1 (imperial dimensions)

DRIVE FLANGE D3

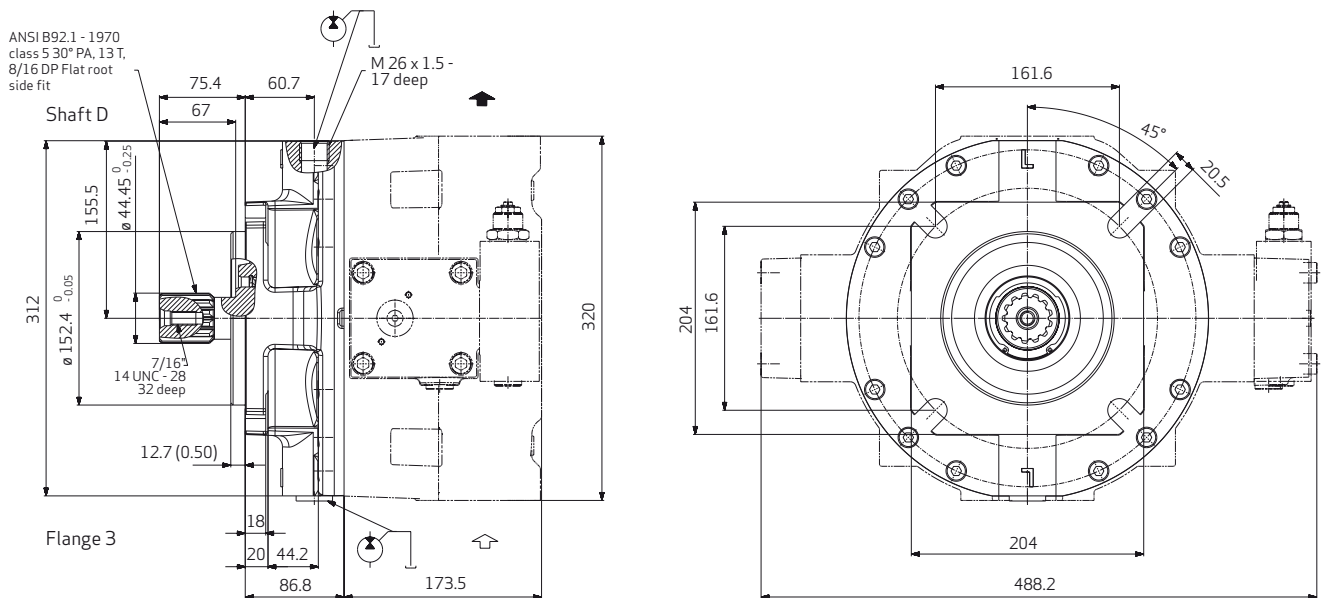

Involute spline according to SAE 744 C (for RKP mounting obligatory)
 SAE mounting flange to DIN ISO 3019/1 (imperial dimensions)

RADIAL PISTON PUMPS RKP-II FOR LOW-FLAMMABILITY FLUIDS

APPENDIX B – TECHNICAL DRAWINGS DRIVE FLANGES RKP 140

INTERMEDIATE FLANGE RKP 140-140

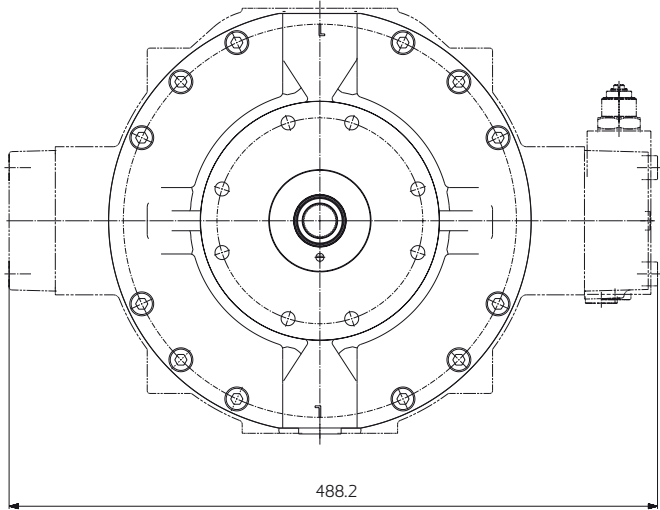
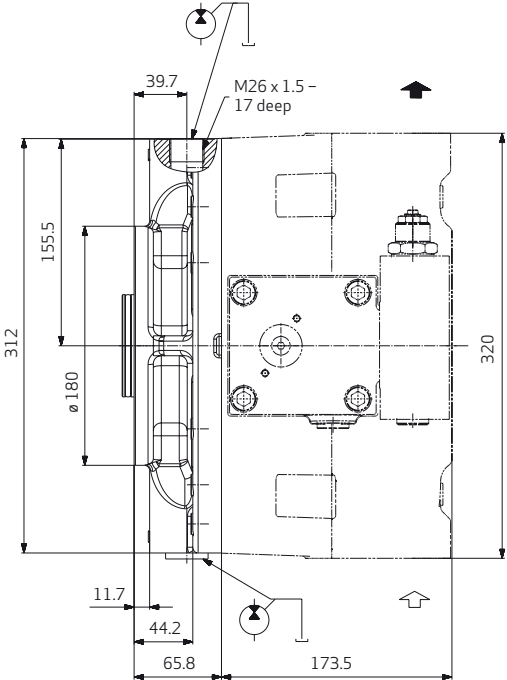

RADIAL PISTON PUMPS RKP-II FOR LOW-FLAMMABILITY FLUIDS

APPENDIX B – TECHNICAL DRAWINGS COMPENSATORS RKP-II 140

PRESSURE AND FLOW COMPENSATOR (LOAD SENSING) WITH P-T LAND, R1

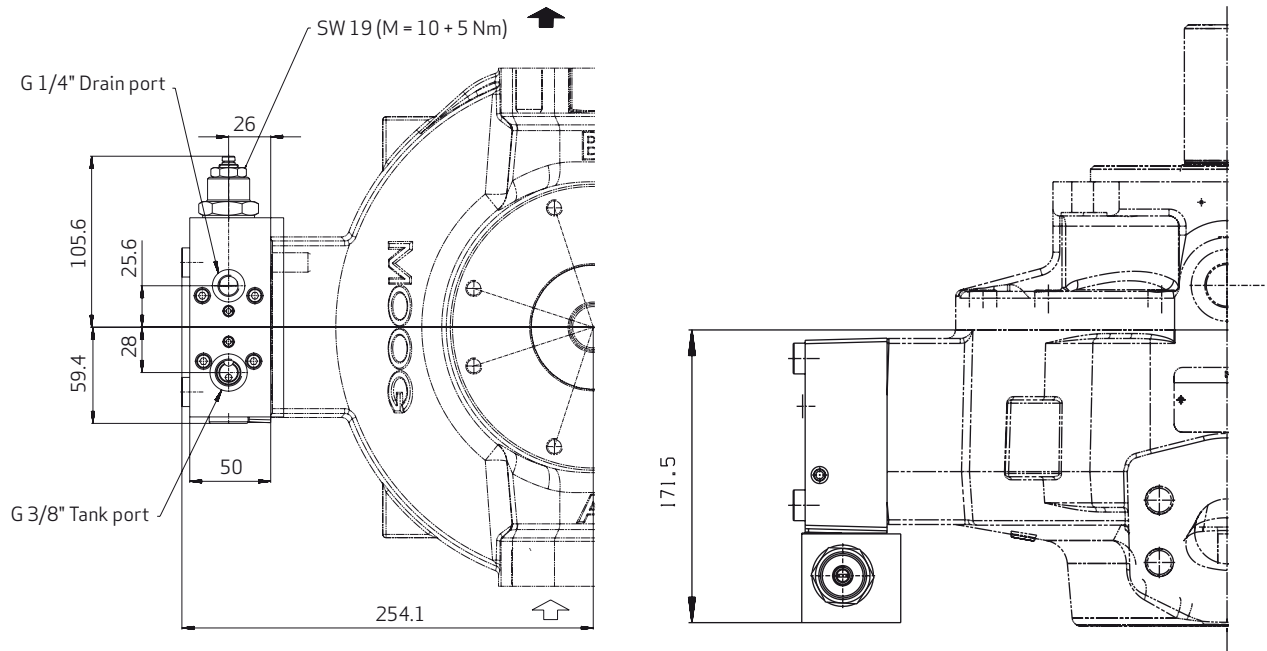

Caution!

The tank line of the compensator must not be combined with the drain line of the pump.

Following circuits are illustrated

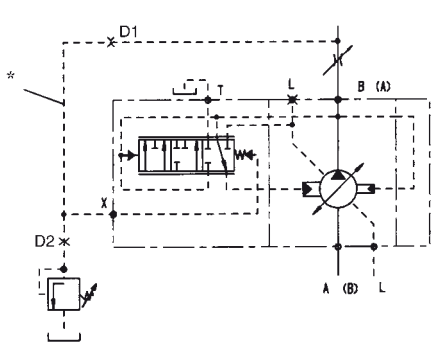

Pressure and flow compensation
"load sensing"

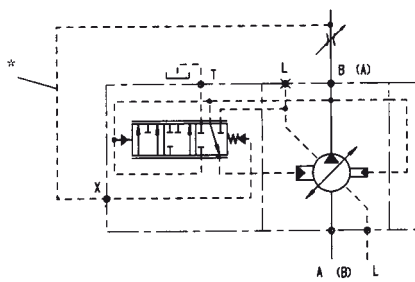

Flow compensation

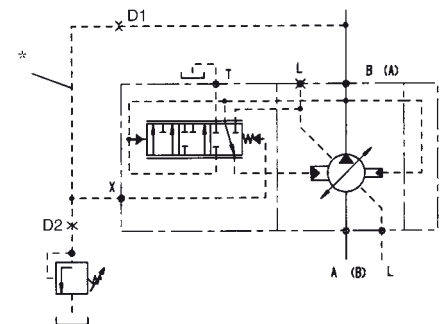

Pressure compensation activated

* Recommendation: Hose for pilot oil line

Notes on multiple pump circuits

In the case of multiple pumps which deliver into one circuit, the P-T land may only be activated for the compensator of the first pump by connecting the tank port to the tank. The tank port of the compensators of add-on pumps must be plugged.

		D1 [mm] ([in])	D2 [mm] ([in])
RKP 140	DN 8	0.8 (0.031)	1.1 (0.043)
l = 800 mm (31.50 in)			

RADIAL PISTON PUMPS RKP-II FOR LOW-FLAMMABILITY FLUIDS

APPENDIX B – TECHNICAL DRAWINGS COMPENSATORS RKP-II 140

ELECTRO-HYDRAULIC CONTROL WITH DIGITAL ON-BOARD ELECTRONICS D

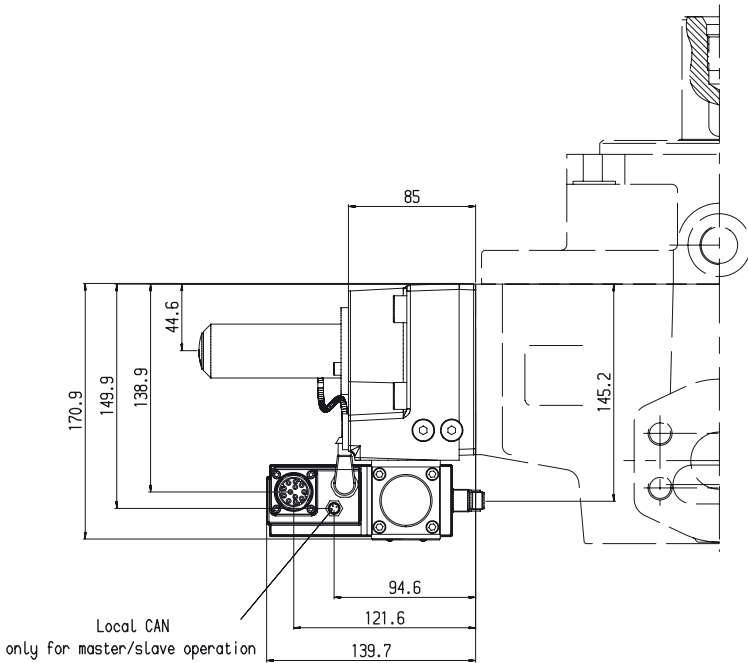
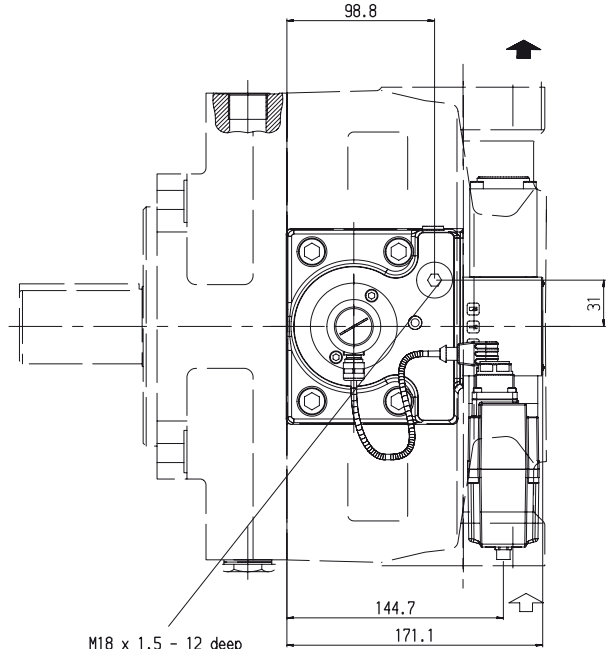
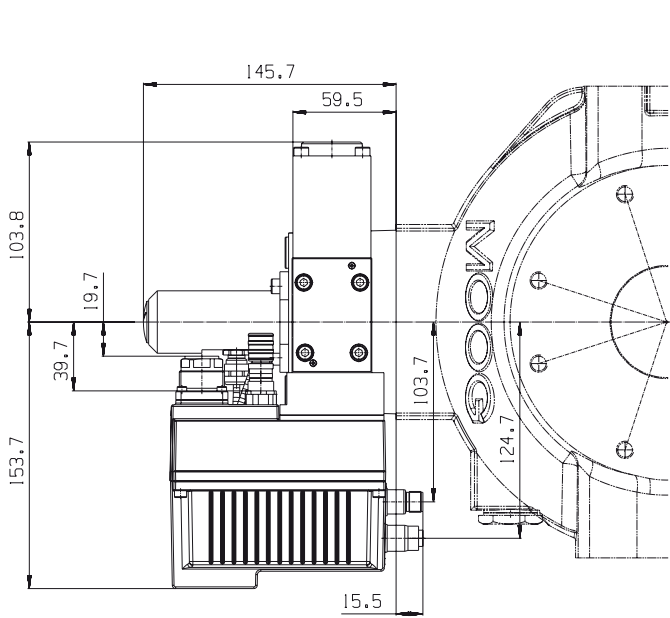

RADIAL PISTON PUMPS RKP-II FOR LOW-FLAMMABILITY FLUIDS

APPENDIX B – TECHNICAL DRAWINGS COMPENSATORS RKP-II 140

MAXIMUM FLOW LIMITER Y

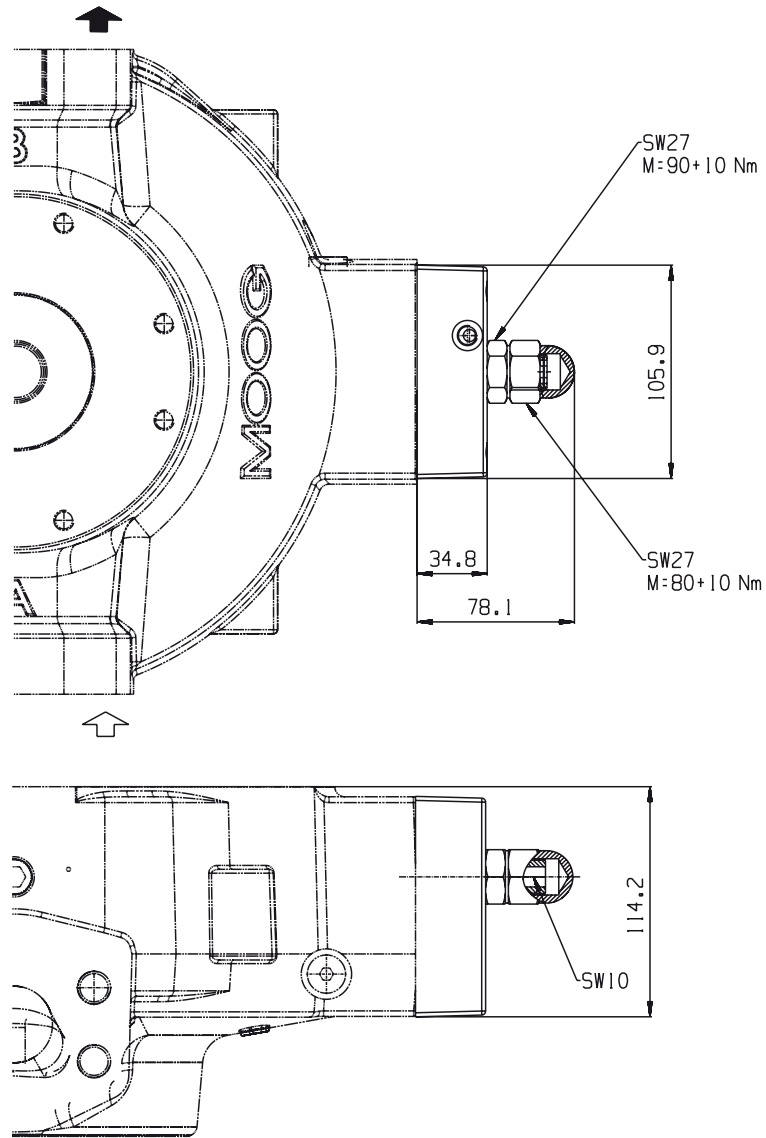

V [cm ³ /rev] ([cu.in/rev])	140 (8.54)
ΔV for 1 mm (0.039 in) travel adjusting screw (pitch 1.5 mm/rev (0.059 in/rev))	11.5 (0.70)

RADIAL PISTON PUMPS RKP-II FOR LOW-FLAMMABILITY FLUIDS

APPENDIX B – TECHNICAL DRAWINGS COMPENSATORS RKP-II 140

MECHANICAL STROKE ADJUSTMENT B

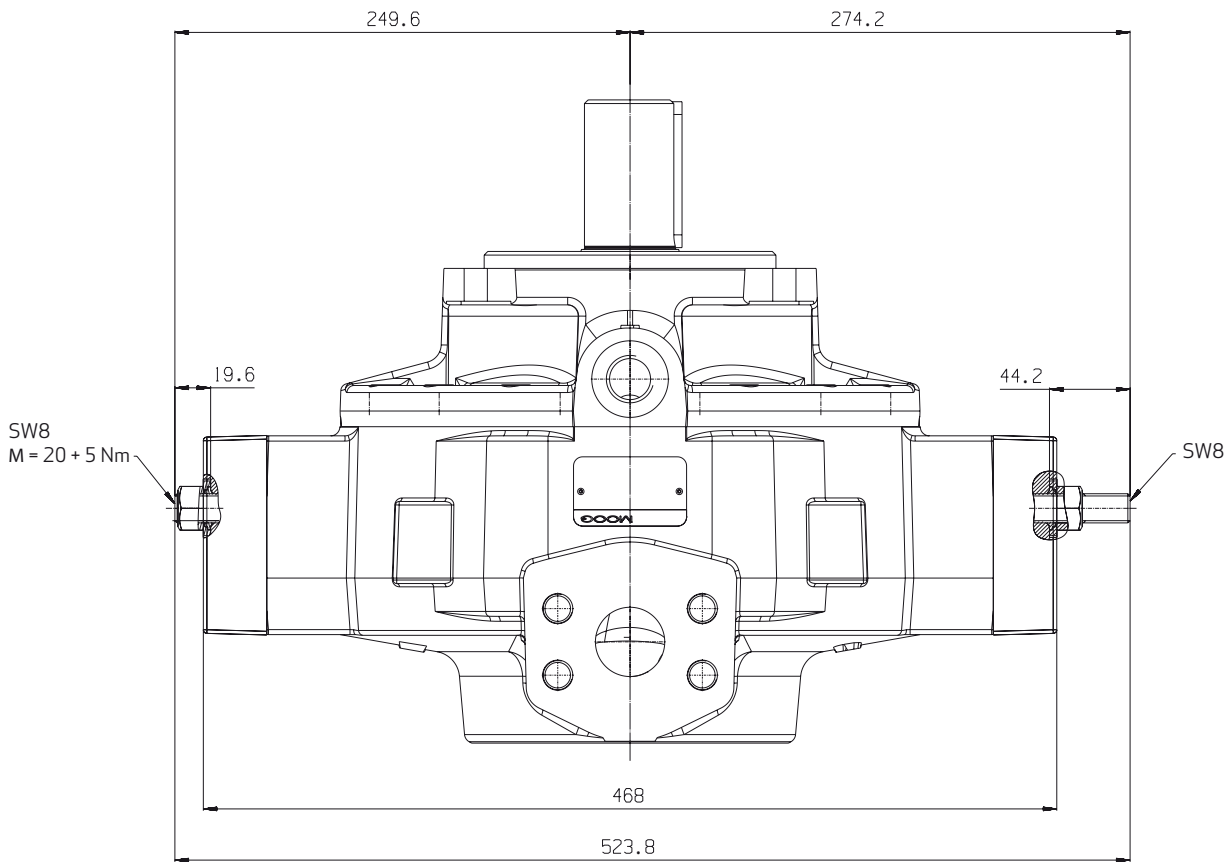
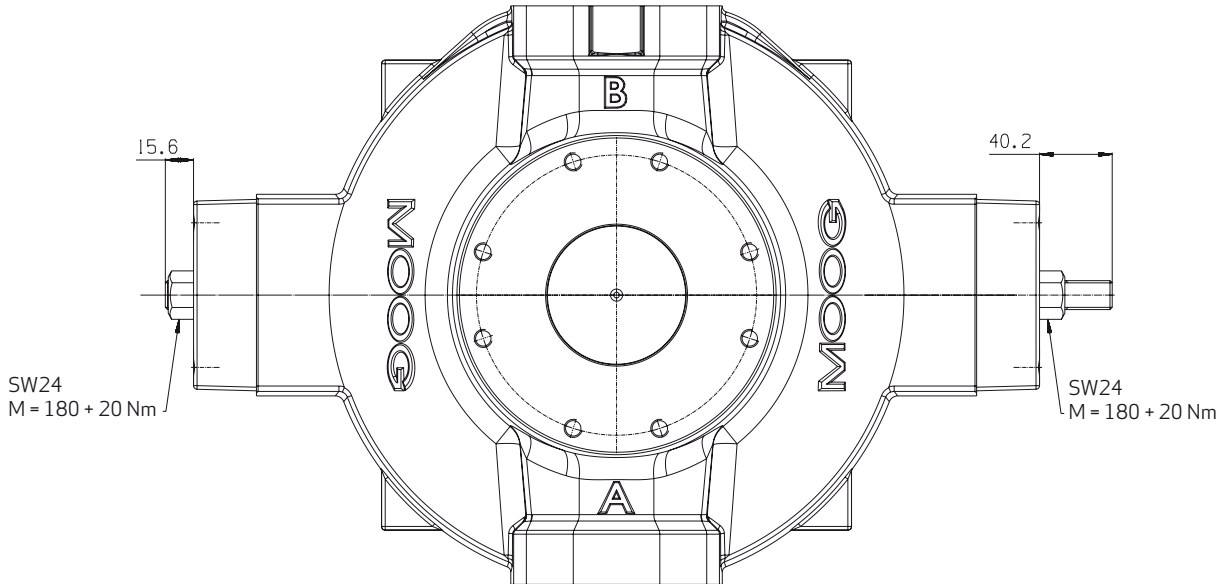

V [cm³/rev] ([cu.in/rev])	140 (8.54)
ΔV for 1 mm (0.039 in) travel adjusting screw (pitch 1.5 mm/rev (0.059 in/rev))	11.5 (0.70)

RADIAL PISTON PUMPS RKP-II FOR LOW-FLAMMABILITY FLUIDS

MOOG GLOBAL SUPPORT AND FURTHER INFORMATION

MOOG GLOBAL SUPPORT

Moog Global Support™ is our promise to offer world-class Repair and Maintenance Services delivered expertly by our trained technicians. With the reliability only available from a leading manufacturer with facilities around the world, Moog offers you service and expertise you can count on to keep your equipment operating as it should.

This promise offers many benefits to our customers including:

- Reduce your downtime by keeping critical machines running in peak performance
- Protect your investment by ensuring reliability, versatility and long-life of products
- Better plan your maintenance activities and make systematic upgrades
- Leverage our flexible programs to meet unique service requirements of your facility

Look to Moog for global support including:

- Repair services using OEM parts are performed by trained technicians to the latest specifications
- Stock management of spare parts and products to prevent unplanned downtime
- Flexible programs, tailored to your needs such as upgrades, preventative maintenance and annual/multi-year contracts
- On-site services bring the expertise to you, providing quicker commissioning, set-up and diagnostics
- Access to reliable services that are guaranteed to offer consistent quality anywhere in the world

For more information on Moog Global Support™, visit www.moog.com/industrial/service.



TAKE A CLOSER LOOK.

Moog solutions are only a click away. Visit our worldwide Web site for more information and the Moog facility nearest you.

Argentina
+54 11 4326 5916
info.argentina@moog.com

Ireland
+353 21 451 9000
info.ireland@moog.com

Spain
+34 902 133 240
info.spain@moog.com

Australia
+61 3 9561 6044
info.australia@moog.com

Italy
+39 0332 421 111
info.italy@moog.com

Sweden
+46 31 680 060
info.sweden@moog.com

Brazil
+55 11 3572 0400
info.brazil@moog.com

Japan
+81 46 355 3767
info.japan@moog.com

Switzerland
+41 71 394 5010
info.switzerland@moog.com

Canada
+1 716 652 2000
info.canada@moog.com

Korea
+82 31 764 6711
info.korea@moog.com

United Kingdom
+44 168 429 6600
info.uk@moog.com

China
+86 21 2893 1600
info.china@moog.com

Luxembourg
+352 40 46 401
info.luxembourg@moog.com

USA
+1 716 652 2000
info.usa@moog.com

Finland
+358 10 422 1840
info.finland@moog.com

Netherlands
+31 252 462 000
info.thenetherlands@moog.com

France
+33 1 4560 7000
info.france@moog.com

Norway
+47 6494 1948
info.norway@moog.com

Germany
+49 7031 622 0
info.germany@moog.com

Russia
+7 831 713 1811
info.russia@moog.com

Hong Kong
+852 2 635 3200
info.hongkong@moog.com

Singapore
+65 677 36238
info.singapore@moog.com

India
+91 80 4057 6605
info.india@moog.com

South Africa
+27 12 653 6768
info.southafrica@moog.com

www.moog.com/industrial

Moog is a registered trademark of Moog, Inc. All trademarks as indicated herein are the property of Moog Inc. and its subsidiaries. All rights reserved.
Viton is a registered trademark of DuPont.
©2010 Moog Inc.

Radial Piston Pump RKP-II for low-flammability fluids
GUT/PDF/Rev. 3.1, May 2010, Id. CDL28651-en