

# SERVOVALVES

## SERIES D636/D638

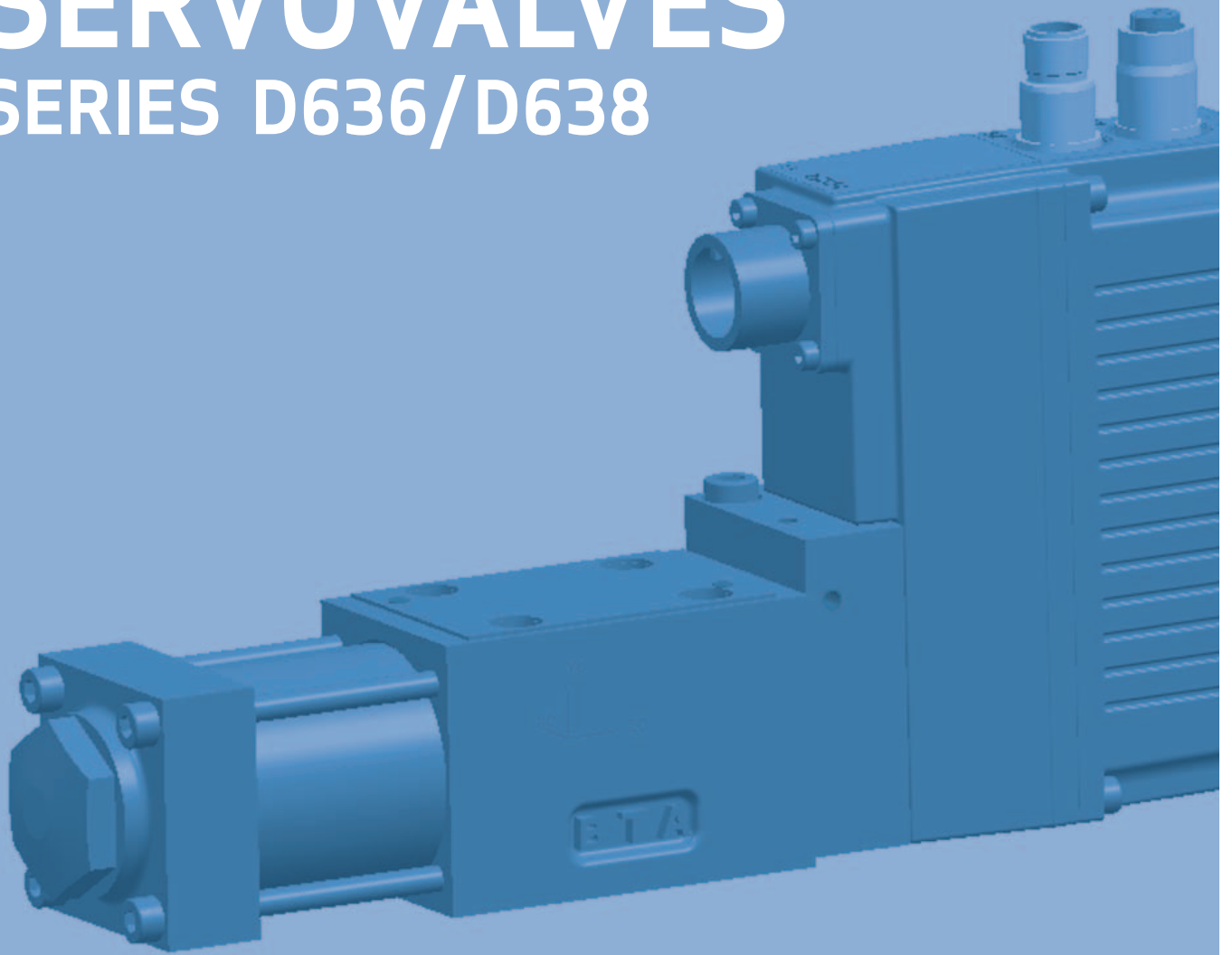

DIRECT DRIVE SERVOVALVES  
WITH INTEGRATED DIGITAL ELECTRONICS  
AND OPTIONAL FIELD BUS INTERFACE

CHAPTER	PAGE
General overview	2
Benefits and function	3
Functional description	4
Operating modes	5
Electronics	6
Hydraulics with field bus	10
Configuration Software	11
Technical data	12
Performance curves	13
Installation drawings	14
Accessories	16
Ordering information	17
Global support	19

## EXCELLENCE IN DRIVE TECHNOLOGY

For over 50 years Moog has ranked amongst the leading providers of drive technology with a focus on the production and application of high performance products. Today, Moog offers innovative products using state of the art control techniques that contribute to the performance improvement of machines.

## MOOG SERVO AND PROPORTIONAL VALVES

Moog Germany has been producing servo and proportional valves with integrated electronics for over 30 years. During this period, more than 200.000 valves have been delivered. Our servo and proportional valves are successfully used in all kinds of applications in machine and plant construction.

## DIRECT DRIVE SERVOVALVES

The D636 series (flow control valves) and the D638 series (flow and pressure control valves) are direct drive servovalves (DDV - Direct Drive Valve). The valves are throttle control valves for 3- (2-, 4-, 2x2-) way applications and are suitable for electro-hydraulic control of position, speed, pressure and force even under high dynamic requirements.

## DESIGN AND APPLICATIONS

A permanent magnet linear force motor is used to drive the spool. In contrast to proportional solenoid drives, the linear force motor drives the spool in both working directions from the spring-centred middle position. This gives the Moog servovalve strong actuating force for the spool, as well as good static and dynamic characteristics.

Our Quality Management System conforms to DIN EN ISO 9001.

## NOTICE

This catalogue is for users with some technical knowledge. To ensure that all necessary characteristics for function and safety of the system are given, the user must check the suitability of the products described herein. Product descriptions provided herein are subject to changes that may be made without prior notification. In case of doubt, please contact Moog.

Moog is a registered trademark of Moog Inc. and its subsidiaries. Unless stated otherwise, all trademarks mentioned herein are the property of Moog Inc. and its subsidiaries. For the full disclaimer refer to

[www.moog.com/literature/disclaimers](http://www.moog.com/literature/disclaimers).

©Moog Inc. 2006. All rights reserved. Changes reserved

For the most current information, visit [www.moog.com/industrial](http://www.moog.com/industrial)

- Before commissioning, the complete hydraulic system must be flushed and the hydraulic fluid must be filtered.
- Please read the notes in section entitled "Electronics", page 6.
- In the same way as new valves, repaired valves/exchange valves will be shipped with factory default settings. Prior to commissioning the valves, check for correct configuration and any potentially changed parameters

**Q-, p-, pQ-FUNCTIONALITY**

The valves provide full Q-(D636), p-(D638) and pQ-functionality (option, D638). By using the pQ option of the D638 series, the control of flow and pressure is possible with just one valve. The selection of the p or Q control mode is made via the field bus interface.

**DIGITAL ELECTRONICS**

The digital driver and control electronics are integrated into the valve. The valve electronics contain a microprocessor system, which performs all important functions via the valve software it contains. The digital electronics enables the valve to be controlled across the full range of operation, with significantly reduced influence from temperature and drift.

**FIELD BUS INTERFACE**

A built-in field bus interface (CANopen, Profibus DP V1 or EtherCAT) enables operating parameters to be set, activates the

valve and monitors its performance. To reduce wiring, the field bus interface is provided with two connectors. Thus, valves may be integrated into the bus without any external T-joints. In addition, up to two analogue input commands and up to two analogue actual value outputs are available.

Optionally, the valves are available without a field bus interface. In this case, the valve is controlled using analogue inputs. Valve parameters are set using the integrated M8 service connector.

**USER ADAPTABILITY**

In addition, the axis control functionality such as position control, velocity control and force control etc. can be added to the valves. The control mode can be switched over from one to the other by defined events.

Our application engineers will be happy to assist you with any additional information you may require.

**BENEFITS OF D636/D638 SERIES DIRECT DRIVE SERVOVALVES**

- Field bus data connection: Electrically isolated field bus interface
- Diagnosis options: Integrated monitoring of the most important environmental and internet parameters; valve parameters may be changed on site or remotely
- Flexibility: Since parameters may be downloaded using the field bus or a high level PLC program, valve parameters may be tuned during a machine cycle while the machine is operating
- Pressure control configuration: Up to 16 configurations may be saved and can be activated during operation
- Volume flow and pressure control (D638) using a single servo-valve
- Direct drive with permanent magnet linear force motor that provides high actuating force, works in 2 directions
- Pilot oil not required
- Pressure independent dynamics
- Minimal hysteresis and high response characteristics
- Minimal current requirement at and close to hydraulic null (hydraulic null is the position of the spool at which the pressures of a symmetrical spool are equal in both blocked control ports)
- If the electrical supply fails, a cable breaks or emergency stop is activated, the spool returns to the predefined spring-centred position without passing a fully open control port position (fail-safe)

**D636 SERIES SINGLE STAGE DIRECT DRIVE SERVOVALVE**

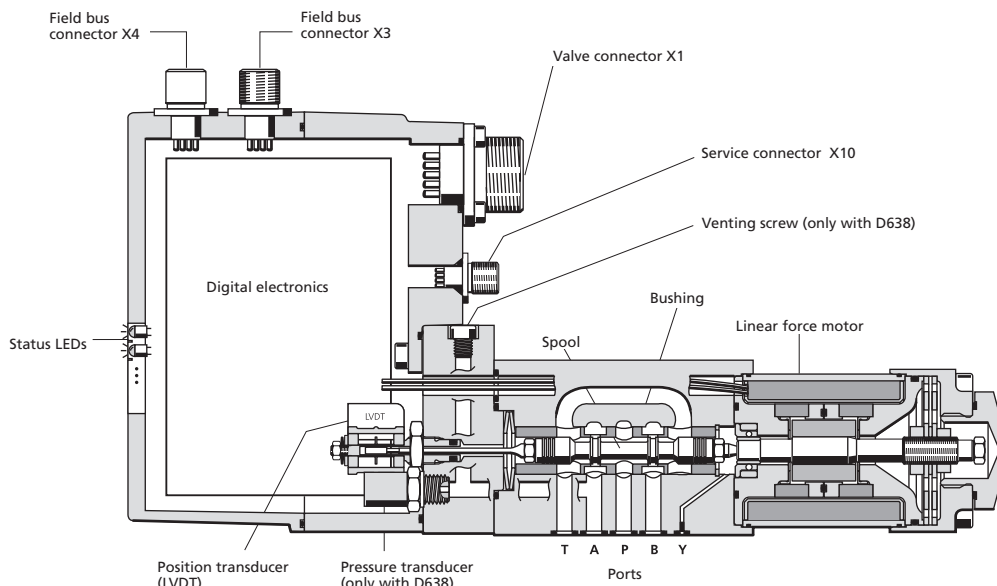

# FUNCTIONAL DESCRIPTION

# D636/D638

## FUNCTIONALITY OF THE LINEAR FORCE MOTOR

The linear force motor is a permanent magnet excited differential motor. A portion of the magnetic force comes from the permanent magnet. This makes the linear force motor's power requirement considerably lower than that of comparable proportional solenoid.

The linear force motor drives the spool of the servo-proportional valve. In the zero current condition, the centering springs determine the starting position of the spool. The linear force motor enables the spool to be moved in both directions. The linear force motor's force is proportional to the coil current.

The strong forces from the linear force motor and the centering springs enable precise movement of the spool, even when working against flow and frictional forces.

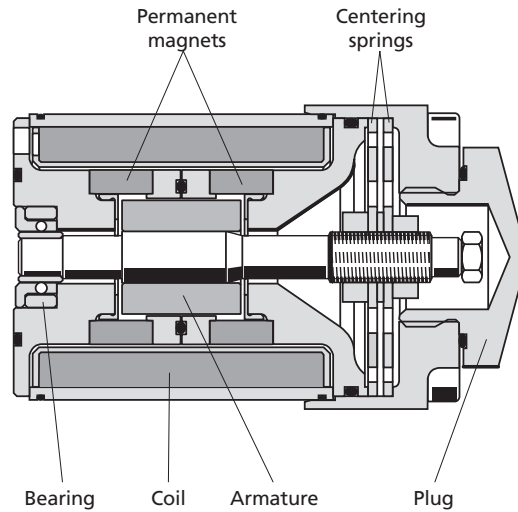

## 4-WAY AND 3-WAY OPERATION

In 4-way operation, the servo-proportional valves can be used to control the flow in ports A and B (use as throttle valves). To obtain 3-way operation, close either port A or port B. If the pressure in the tank port T exceeds 50 bar (715 psi), the leakage port Y must be used. The valves are available with zero lap, less than 3% or 10% positive lap.

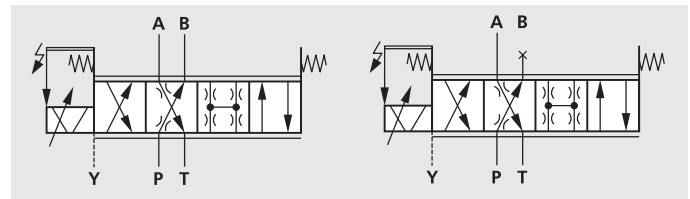

4-way/3-way-operation with failsafe function (hydraulic symbols)

## 2-WAY AND 2X2-WAY OPERATION

In 2-way and 2x2-way operation, the servo-proportional valves can be used to control the flow in one direction (use as throttle valves). In 2x2-way operation, the valve can be used in 2-way applications for higher flows. To do this, the port P must be connected externally to B and A externally to T.

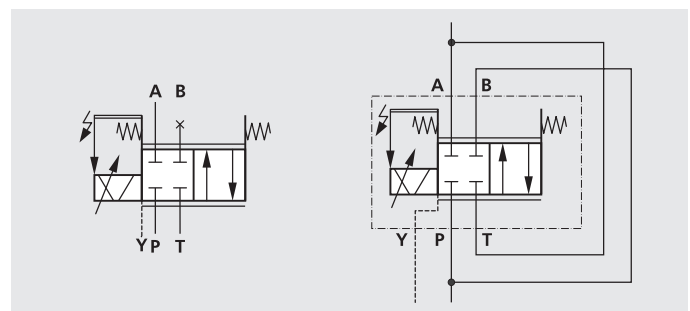

2-way and 2x2-way operation (hydraulic symbols)

**OPERATIONAL MODES FOR SERVOVALVES**

**FLOW CONTROL (Q-CONTROL)**

In this operating mode, the actual spool position is controlled. The spool position is proportional to the command signal. The command signal (spool position command) is fed to the valve electronics. A position transducer (LVDT) measures the spool's actual position and forwards this information to the valve electronics. The electronics compares the actual spool position and command signal and generates a signal to drive the linear force motor, which then brings the spool into the correct position.

The position command can be modified by parameters in the valve software (i.e., linearization, ramping, dead band, sectionally defined amplification, etc).

**FLOW CONTROL AND PRESSURE CONTROL (pQ-CONTROL) (optional for D638)**

This is a combination of flow and pressure control for which both command signals (flow and pressure command) must be present. During the pQ function, the required spool position calculated by the pressure controller is compared to the external spool position command. The smaller of the two is fed into the spool position control loop.

**PRESSURE CONTROL (p-CONTROL)**

In this operating mode of the D638 valve, the pressure in port A is controlled. The pressure in port A is proportional to the pressure command signal. The command signal (pressure command for port A) is transmitted to the valve electronics. A pressure transducer measures the pressure in port A and feeds this to the valve electronics. The electronics compare the actual pressure signal and the command signal and then generate an internal signal to drive the linear force motor, which then brings the spool into the correct position.

The pressure control function can be modified by parameters in the valve software (i.e. linearization, ramping, etc.). The pressure regulator operates as an extended PID controller. In the valve software, you can set the parameters of the PID controller.

The result of this action is to give spool position control until the actual pressure starts to exceed the pressure command, at which point pressure control takes over.

The following are examples of possible combinations:

- Flow control with pressure limiting control
- Forced changeover from one operating mode to the other

**VALVE FLOW CALCULATIONS**

The actual valve flow is dependent on the spool and the pressure drop  $\Delta p$  across the spool lands.

At 100% command signal the valve flow at rated pressure drop  $\Delta p_N = 35 \text{ bar (500 psi)}$  per metering land is the rated flow  $Q_N$ . For other than rated pressure drop, the valve flow changes at a constant command signal according to the following formula.

$$Q = Q_N \cdot \sqrt{\frac{\Delta p}{\Delta p_N}}$$

$Q$  [l/min] = actual flow  
 $Q_N$  [l/min] = rated flow  
 $\Delta p$  [bar] = actual valve pressure drop  
 $\Delta p_N$  [bar] = rated valve pressure drop

$Q_{max} = 75 \text{ l/min (19.5 gals/min)}$

The actual valve flow  $Q$  must not exceed a mean velocity of  $30\text{m/s (96.54 ft/s)}$  in the port P, A, B and T.

**VALVE FLOW DIAGRAM**

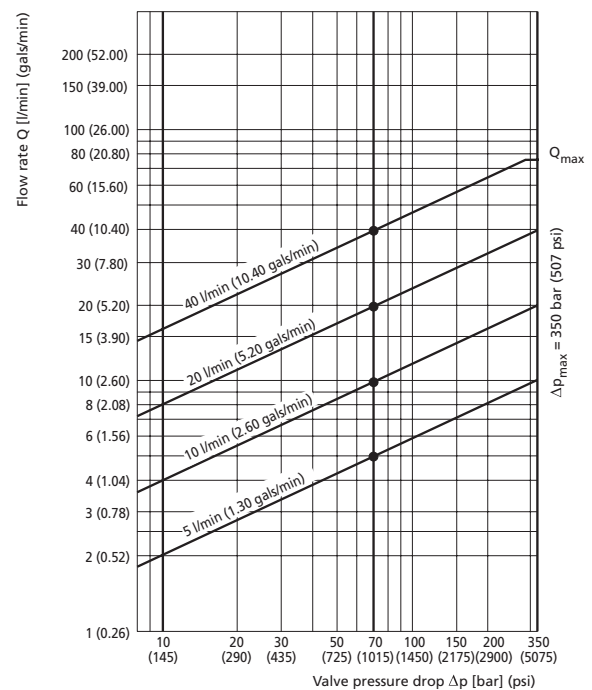

**GENERAL REQUIREMENTS FOR VALVE ELECTRONICS**

- Supply 24 V DC, min. 18 V DC, max. 32 V DC
- All signal lines, as well as those of external transducers, to be shielded
- Shielding connected radially to  $\perp$  (0 V), power supply side, and connected to the mating connector housing (EMC)
- **EMC:** Meets the requirements of immunity: DIN EN 61000-6-2:2005 (criterion A) and emission according to DIN EN 61000-6-4:2005 (EtherCAT according to DIN EN 61000-6-3:2005)
- External fusing 1.6 A slow blow
- Duty cycle 100%

- Max. power consumption 28.8 W (1.2 A at 24 V DC)
- Minimum cross-section of leads  $\geq 0.75 \text{ mm}^2$  (0.03 in<sup>2</sup>) other signal lines  $\geq 0.25 \text{ mm}^2$  (0.01 in<sup>2</sup>). Consider voltage losses between cabinet and valve. See also Moog technical note TN 494
- Note: When making electrical connections to the valve (shield, protective earth), appropriate measures must be taken to ensure that locally different earth potentials do not result in excessive earth currents. See also Moog technical note TN 353

**SIGNAL AND WIRING FOR VALVES WITH ANALOGUE ACTIVATION AND CONTROL**

**Valves with current command input**

**Command signal 0...10 mA (p function), floating**

**Command signal 0...±10 mA (Q function), floating,**

The spool stroke of the valve in Q mode (flow control) is proportional  $I_D = -I_E$  for a 6+PE connector and  $I_4 = -I_5$  (for  $I_7 = 0$ ) for an 11+PE connector.

The command signal  $I_D = +10 \text{ mA}$  or  $I_4 = +10 \text{ mA}$  equals 100% valve opening  $P \rightarrow A$  and  $B \rightarrow T$ .

At 0 mA command the spool is in center position. For D638 in pressure mode (0...10 mA) or the pressure in port A of the valve is proportional to  $I_D = -I_E$  for a 6+PE connector and  $I_7 = -I_5$  (for  $I_4 = 0 \text{ mA}$ ) for an 11+PE connector.  $I_D = +10 \text{ mA}$  or  $I_7 = +10 \text{ mA}$  equals 100 % regulated pressure in port A.

**Command signal 4...20 mA (p and Q function), floating**

The spool stroke of the valve in Q mode (flow control) is proportional  $I_D = -I_E$  for a 6+PE connector and  $I_4 = -I_5$  (for  $I_7 = 0$ ) for an 11+PE connector.

The command signal  $I_D = 20 \text{ mA}$  or  $I_4 = 20 \text{ mA}$  equals 100% valve opening  $P \rightarrow A$  and  $B \rightarrow T$ .

At 12 mA command the spool is in center position. For D638 in pressure mode (4...20 mA) the pressure in port A of the valve is proportional to  $I_D = -I_E$  for a 6+PE connector and  $I_7 = -I_5$  (for  $I_4 = 0 \text{ mA}$ ) for an 11+PE connector.  $I_D = +20 \text{ mA}$  or  $I_7 = +20 \text{ mA}$  equals 100 % regulated pressure in port A.

**Valves with voltage command input**

**command input 0...10 V (p function), floating,**

**command input 0...±10 V (Q function), floating,**

The spool stroke of the valve in Q mode (flow control) is proportional  $(U_D - U_E)$  for a 6+PE connector and  $(U_4 - U_5)$  for an 11+PE connector.

The command signal  $(U_D - U_E) = +10 \text{ V}$  or  $(U_4 - U_5) = +10 \text{ V}$  equals 100 % valve opening  $P \rightarrow A$  and  $B \rightarrow T$ .

For 0 V command the spool is in center position. For D638 in pressure mode (0...10 V) the pressure in port A of the valve is proportional to  $(U_D - U_E)$  for a 6+PE connector and  $(U_7 - U_5)$  for an 11+PE connector.  $(U_D - U_E) = +10 \text{ V}$  and  $(U_7 - U_5) = +10 \text{ V}$  equals 100 % regulated pressure in port A

**Actual value 4...20 mA**

The actual spool position value, that is the position of the spool in Q mode and the pressure in port A for pressure mode can be measured at pin F for a 6+PE connector (see diagrams below) and pins 6 and 8 for an 11+PE connector. These signals can be used for monitoring and fault detection purposes. The spool stroke and pressure range respectively corresponds 4...20 mA. At 12 mA the spool is in center position. 20 mA equals 100% valve opening  $P \rightarrow A$  and  $B \rightarrow T$ .

The position signal output 4...20mA allows the detection of a cable break when  $I_{out} = 0 \text{ mA}$ .

**Circuit diagram for measurement of actual value  $I_F$  (position of spool for D636 and pressure in port A for D638) for valves with 6+PE connector**

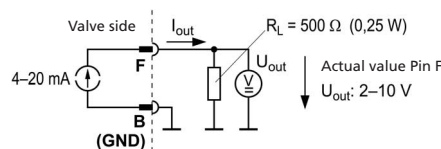

**Circuit diagram for measurement of actual value  $I_{out6}$  (position of spool for D636 and pressure in port A for D638) and  $I_{out8}$  (pressure in port A) for valves with 11+PE connector**

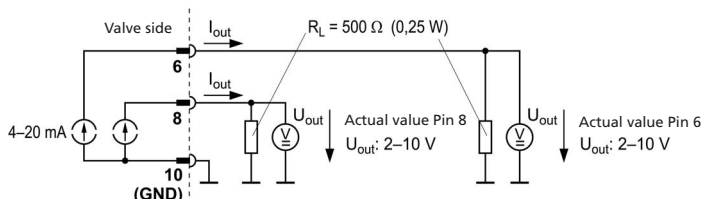

**WIRING FOR VALVES WITH 6+PE CONNECTOR X1**

To EN 175201 part 804, and mating connector (type R and S, metal shell) with leading protective earth connection (⊕).

Pin	Input signal		Voltage floating ±10 V, 0...10 V	Current floating ±10 mA, 0...10 mA, 4...20 mA
	Function			
A	Supply voltage	24 V DC (18...32 V DC) above GND		
B	Power ground/ Signal ground	GND		
C	Enable input	8.5...32 V DC with respect to GND: operation of the valve enabled < 6.5 V DC with respect to GND: Valve fail-safe condition		
D E	Command input	$U_{in} = U_{DE}$ $R_{in} = 20 \text{ k}\Omega$  differential  The potential difference (measured with respect to Pin B) must be between -15V and +32V.	$I_{in} = I_D = -I_E$ $R_{in} = 200 \Omega$  The input current $I_{in}$ of this command input must be between -25 mA and +25 mA!  Command signals $I_{in} < 3 \text{ mA}$ (due to line break, for example) indicate an error for signals 4...20 mA. The valve reaction to this error may be customized and activated by the customer.	
F	Actual value output	$I_{out}$ : 4...20 mA referenced to GND (The signal is proportional to position of the spool for D636 valves and proportional to port A pressure for D638 valves. The output is short circuit protected. For conversion of actual value output signal $I_{out}$ see page 6); $R_L = 0...500 \Omega$ .		
⊕	Protective earth			

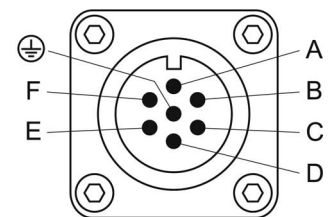

**WIRING FOR VALVES WITH 11+PE CONNECTOR X1**

To EN 175201 part 804, mating connector (metal) with leading protective earth connection (⊕).

Pin	Input signal Function	Voltage floating ±10 V, 0...10 V	Current floating ±10 mA, 0...10 mA, 4...20 mA <sup>1)</sup>
1	Not used		
2	Not used		
3	Enable Input	8.5...32 V DC with respect to GND: operation of the valve enabled < 6.5 V DC with respect to GND: Valve fail-safe condition	
4	Command input Valve flow function	$U_{in} = U_{4-5}$ $R_{in} = 20\text{ k}\Omega$	$I_{in} = I_4 = -I_5$ (for $I_7=0$ ) <sup>2)</sup> $R_{in} = 200\ \Omega$
5	Reference point Input rated command	Reference ground for Pin 4 and 7	common feedback for Pin 4 and 7
6	Actual value output spool position	$I_{out} = 4...20\text{ mA}$ with respect to GND ( $I_{out}$ is proportional to position of the spool; the output is short circuit protected; for conversion of the actual value output signal $I_{out}$ see page 6); $R_L = 0...500\ \Omega$	
7	Command input pressure function	$U_{in} = U_{7-5}$ $R_{in} = 20\text{ k}\Omega$	$I_{in} = I_7 = -I_5$ (for $I_4=0$ ) <sup>2)</sup> $R_{in} = 200\ \Omega$
8	Actual value of output pressure	$I_{out} = 4...20\text{ mA}$ referenced to GND ( $I_{out}$ proportional to pressure in port A; the output is short circuit protected) $R_L = 0...500\ \Omega$	
9	Supply voltage	24 V DC (18...32 V DC) above GND	
10	Supply ground	GND	
11	Digital output	Error monitoring <sup>3)</sup>	
⊕	Protective earth		

The potential difference between pins 4, 5 and 7 (measured against pin 10) must be between -15 and +32 V.

- 1) Command signals  $I_{in} < 3\text{ mA}$  (due to cable break, for example) indicates a failure of 4...20 mA signals. The valve reaction to this failure may be customized and activated by the customer.
- 2) As pin 5 is the common feedback for pins 4 and 7,  $-I_5 = I_4 + I_7$  applies.
- 3) Output may be factory programmed, "low" means error (e.g., difference between command value and actual value)

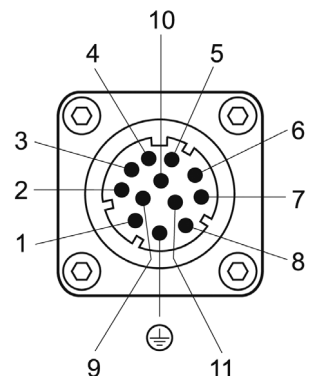



**CAN-MOUNTED CONNECTORS (X3, X4 / CODING A / 2 X M12X1 / 5-POLE)**

Pin	Signal X3, X4	
1	CAN_SHLD	Shielding
2	CAN_V+	Not connected in the valve
3	CAN_GND	Ground
4	CAN_H	Transceiver H
5	CAN_L	Transceiver L

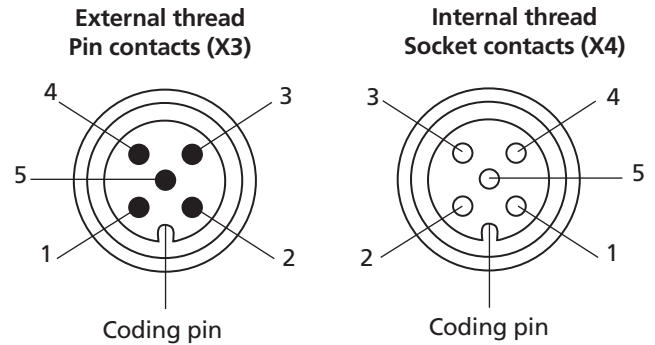

View on mating face of the external mating connector

**PROFIBUS-DP-MOUNTED CONNECTORS (X3, X4 / CODING B / 2 X M12X1 / 5-POLE)**

Pin	Signal X3, X4	
1	Profi V+	Supply voltage for 5 V term. res.
2	Profi A	Receipt/send data -
3	Profi GND	Ground
4	Profi B	Receive/send data +
5	Shield	Shielding

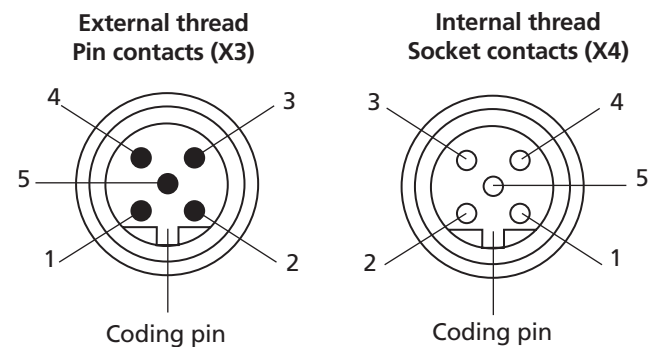

View on mating face of the external mating connector

**ETHERCAT-IN/OUT-MOUNTED CONNECTORS (X3, X4 / CODING D / 2 X M12X1 / 4-POLE)**

Pin	Signal X4 IN	Signal X3 OUT
1	TX + IN	TX + OUT
2	RX + IN	RX + OUT
3	TX - IN	TX - OUT
4	RX - IN	RX - OUT

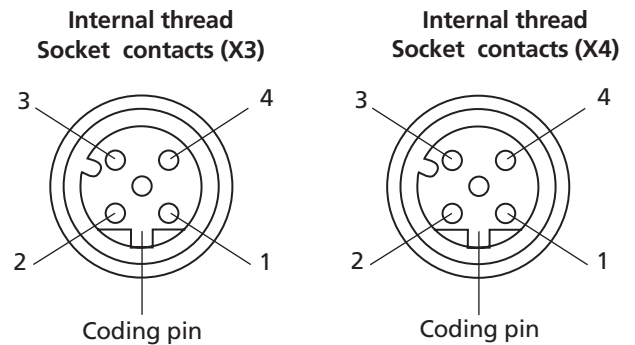

View on mating face of the external mating connector

---

## GENERAL

Modern automation technology is characterised by an increasing decentralization of processing functions via serial data communication systems.

The use of serial bus systems instead of conventional communication technology ensures the increased flexibility of systems in terms of modifications and expansions.

It also has a tremendous potential for savings in project and installation costs in many areas of industrial automation.

Amongst the benefits that have become viable through the use of field bus are additional options for parameterization, enhanced diagnosis options and the reduction of variants.

---

## VDMA PROFILE

In one working group within the German Machinery and Plant Manufacturers' Association, a VDMA profile was created in collaboration with numerous well-known hydraulic system manufacturers.

This profile describes communication between hydraulic components via a field bus. It defines uniform functions and parameters in a standardized exchange format.

---

## CANopen

According to EN 503254-4

The CAN bus is primarily designed for transmission security and speed and was originally developed for use in automobiles. Due to its robustness, it was going to be used in a variety of industrial applications.

In order to allow interoperability between CAN nodes with varying functionality and from different suppliers, a communication profile was developed from CiA which results in the CANopen standard.

**The CAN bus has the following characteristics:**

- Multi master system: Each participant can transmit and receive.
- Topology: Linear structure with short stub line.
- Network extension and band widths: 25 m (80.4 ft) at 1 MBit/s. Up to 5000 m (16090 ft) at 25 kBit/s
- Addressing type: message-oriented via identifier. Priority assignment of the message via identifier.
- Security; Hamming distance = 6, i.e. up to 6 individual errors/messages are recognized.
- Bus physics: ISO 11898
- Max. number of participants: 127 (may be limited by CAN transceiver capability)

---

## PROFIBUS DP-V1

According to EN 61158

Profibus has been developed for process and production industry and therefore is being supported by many manufacturers of control systems.

**Profibus has the following features:**

- Multi master system: Several masters share access time and initiate communication. Slaves only react to requests.

- Topology: Linear structure with short stub line.
- Network extension and band widths: 100 m (321.8 ft) at 12 MBit/s up to 1200 m (3861.6 ft) at 9.6 kBit/s per segment Repeaters may be used.
- Addressing type: Address oriented. Priority/cycle time assignment of messages by master configuration.
- Bus physics: RS-485 according to EIA-485.
- Max. number of participants: 126.

---

## ETHERCAT

According to IEC/PAS 62407

EtherCAT has been developed as an industry bus based on Ethernet to meet increasing demands regarding cycle time. EtherCAT bus is designed for high data transmission rates and fast cycle times.

**The EtherCAT bus has the following characteristics:**

- Single master system: Master initiates communication. Slaves only react to requests.

- Topology: Line, star, tree and ring structure following the daisy chain principle.
- Network extension and band widths: 100 m (321.8 ft) between participants, 100 MBit/s.
- Addressing type: Address oriented, one datagram for all participants.
- Bus physics: Fast Ethernet 100 Base Tx.
- Max. number of participants: 65535.

## GENERAL

The Windows®-based configuration software “Moog Valve Configurator” enables fast and convenient commissioning, diagnosis and configuration of the valve. Data may be uploaded from the PC to the valve; current settings may be downloaded from the valve to the PC and displayed. The valve can be con-

trolled via graphic control elements. Status information, set values and actual values as well as characteristic lines are displayed graphically. System parameters can be recorded and visualized via an integrated oscilloscope/data logger.

## CONFIGURATION SOFTWARE

### System requirements:

The configuration software can be configured on a PC with the following minimal requirements:

- IBM-PC compatible with 133 MHz
- Windows® 95/98/ME, Windows® NT/2000/XP
- 64 MB RAM
- 40 MB free hard disc capacity
- Monitor 640x480 Pixel resolution
- Keyboard, mouse

### Recommended specification

- IBM-PC compatible with 300 MHz
- Windows® NT/2000/XP

To use the software, the following options are additionally required: (see also accessories list, page 15)

- Free USB port
- USB commissioning module
- Configuration/commissioning cable
- Valve connection cable (6+PE or 11+PE)
- Adapter M8 service socket (not required for field bus CANopen)
- Power adapter 24 V DC/2A
- Configuration/commissioning cable

### Note:

Configuration/commissioning using the “Moog valve configuration software” is performed using the Field Bus socket (field bus CANopen), otherwise (field bus Profibus DP, EtherCAT or analog control) using the integrated M8 service socket.

The software is provided by Moog on request at no charge.

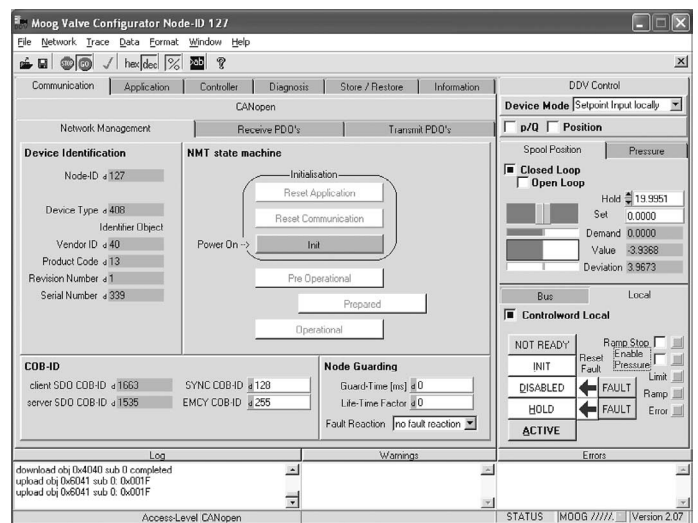

**PERFORMANCE SPECIFICATIONS FOR STANDARD MODELS**

<b>Valve construction type</b>	Single stage, sliding spool with bushing				
<b>Mass</b>	2.5 kg (5.5 lb)				
<b>Mounting pattern</b>	In accordance with ISO 4401-03-03-0-94 (with or without leakage port Y)				
<b>Ø Diameter of the ports</b>	7.9 mm (0.31 in)				
<b>Valve configuration</b>	2-way, 3-way, 4-way, and 2x2-way operation				
<b>Actuation</b>	Directly with permanent magnet linear force motor				
<b>Pilot oil supply</b>	none				
<b>Rated flow <math>Q_N</math></b> (for $\Delta p_N = 35$ bar [500 psi] per spool land)	5 1.3	10 2.6	20 5.2	40 10.4	l/min (dependent on model) gals/min
<b>Max. leakage flow <math>Q_L</math><sup>1)</sup></b>	0.15 0.04	0.3 0.08	0.6 0.16	1.2 0.31	l/min (dependent on model) gals/min
<b>Max. flow</b>	75 l/min (19.5 gals/min)				
<b>Spool lap</b>	Zero lap, < 3% or 10% positive lap (dependent on model)				
<b>Step resp. time for 0 to 100% stroke</b>	8 ms (typical)				
<b>Hysteresis<sup>1) 2)</sup></b>	< 0.05 % (typical)    Max. 0.10 % (Q-Function)				
<b>Null shift</b>	< 1.5 % at $\Delta T = 55$ K (Q-Function)				
<b>Linearity of pressure control (D638)</b>	< 0.5 %				

<sup>1)</sup> At operating pressure  $p_p = 140$  bar (2000 psi), oil viscosity  $\nu = 32$  mm<sup>2</sup>/s (cSt) and oil temperature 40° C (104 °F)

<sup>2)</sup> Hysteresis of p function dependent on controller optimization

**OPERATING CONDITIONS**

<b>Max. operating pressure range</b> Ports P and B Port A Port T without Y Port T with Y Port Y	for D636 for D638	350 bar (5000 psi) Max. 350 bar (5000 psi) dependent on pressure sensor 50 bar (715 psi) 350 bar (5000 psi) Pressureless to tank
<b>Permissible environmental conditions</b> Ambient temperature Vibration resistance Shock resistance		-20°C...+60°C (-4°F...140°F) 30 g, 3 axis, 10 Hz...2 kHz 50 g, 6 directions
<b>Sealing</b>		HNBR, FPM, other on request
<b>Hydraulic fluid</b> Permissible fluids Permissible temperature		hydraulic mineral oil according to DIN 51524, parts 1-3, other on request -20°C...+80 °C (-4°F...176°F)
<b>Viscosity</b> Recommended Permissible		15...100 mm <sup>2</sup> /s (cSt) 5...400 mm <sup>2</sup> /s (cSt)
<b>Clean class, recommended for ...</b> Functional safety Endurance (wear)		ISO 4406 < 18/15/12 ISO 4406 < 17/14/11
<b>Shipping plate</b>		Shipped with an oil tight dust protection cover
<b>Mounting options</b>		In any orientation, consider venting of pressure transducer (D638 only)
<b>Protection class DIN EN60529</b>		IP65 (with mounted mating connectors)
<b>Storage temperature</b>		-20°C...+80°C (-4°F...176°F)

**PERFORMANCE CURVES (TYPICAL) <sup>1)</sup>**

**STEP RESPONSE**

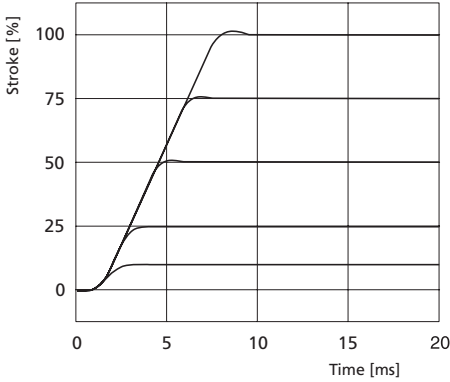

**VALVE FLOW SIGNAL CURVE**

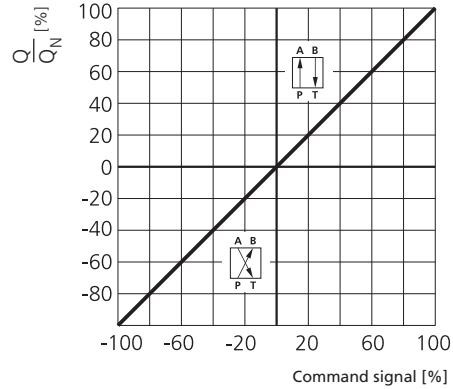

**FREQUENCY RESPONSE**

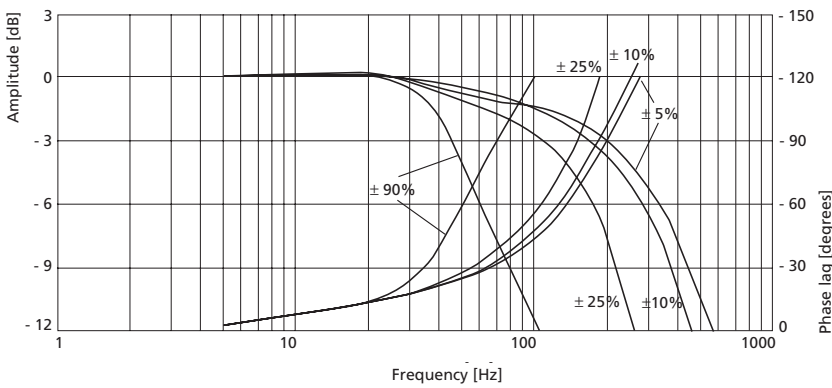

**PRESSURE SIGNAL CURVE (POSITION CONTROLLED VALVE)**

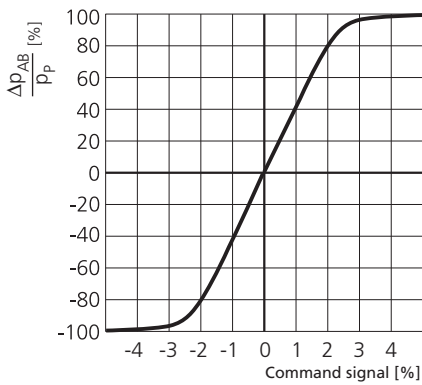

**PRESSURE SIGNAL CURVE (PRESSURE CONTROLLED VALVE) D638**

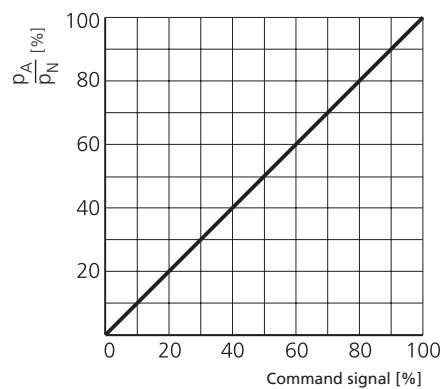

<sup>1)</sup> At operating pressure  $p_p = 140$  bar (2000 psi), oil viscosity  $\nu = 32$  mm<sup>2</sup>/s (cSt) and oil temperature 40° C (104 °F)

**Notice for D638:**

The pressure control electronics must be adapted to the load for each new application Moog provides support on request.

## INSTALLATION DRAWING FOR VALVES WITH CAN FIELD BUS CONNECTOR

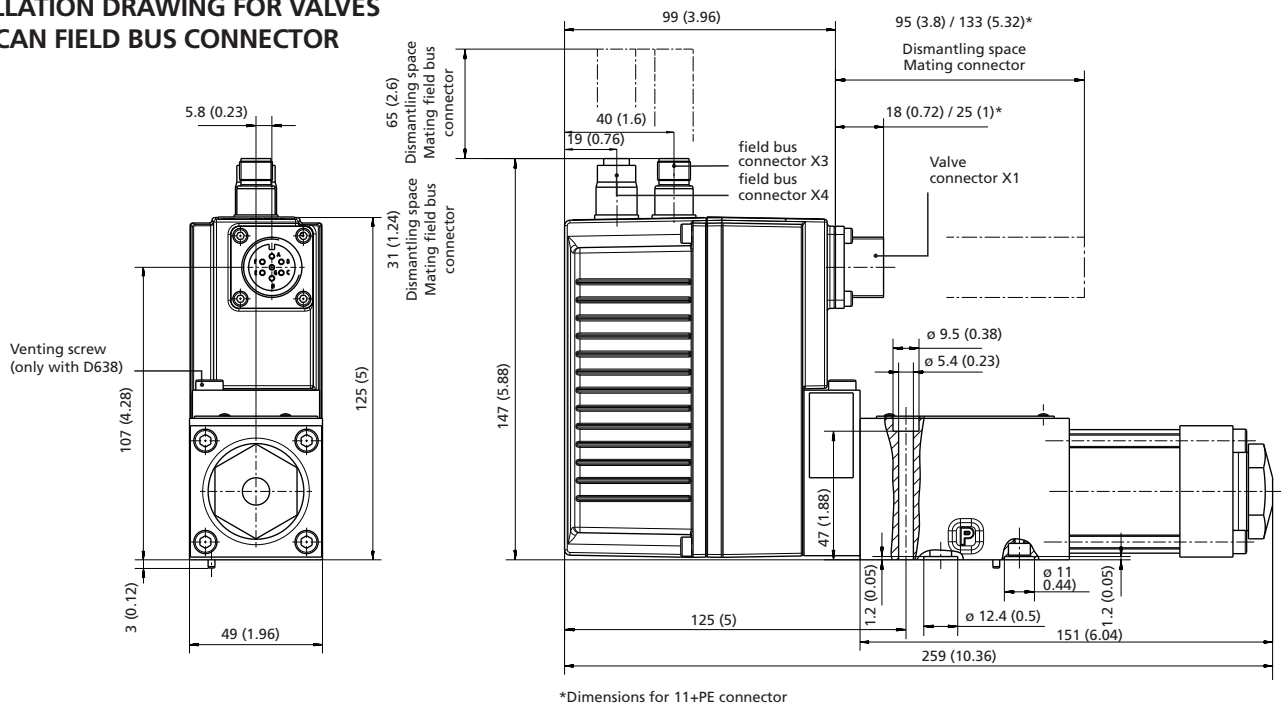

## INSTALLATION DRAWING FOR VALVES WITH PROFIBUS DP OR ETHERCAT FIELD BUS CONNECTOR

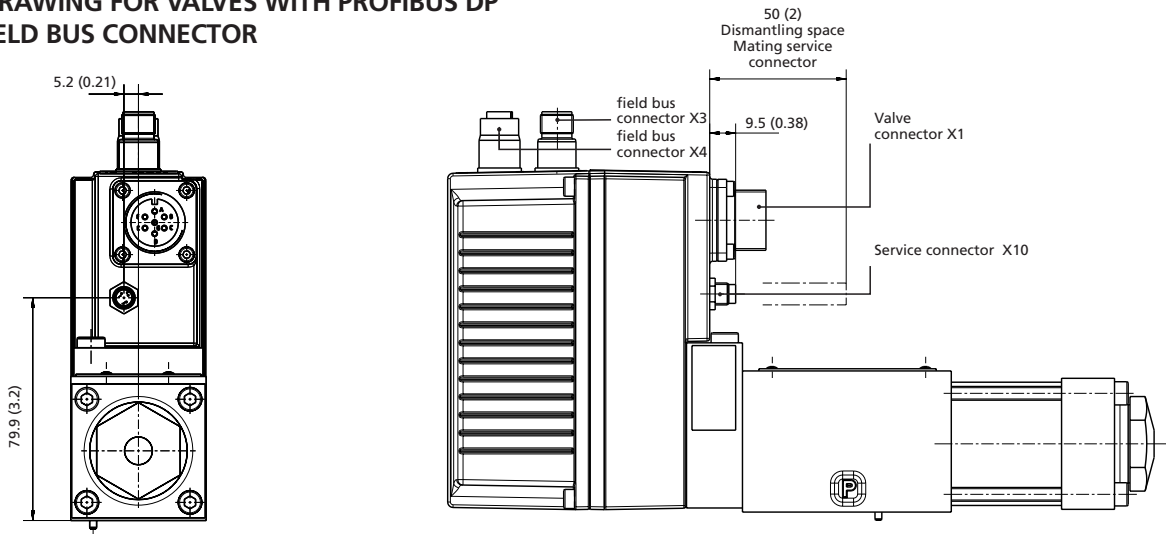

## INSTALLATION DRAWING FOR VALVES WITH ANALOG CONTROL

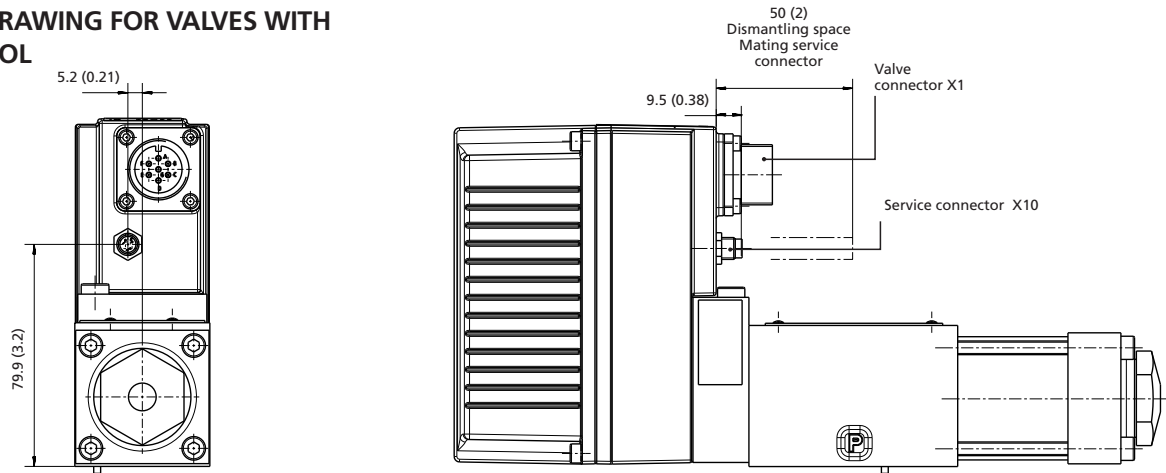

## MOUNTING PATTERN ACCORDING TO ISO 4401-03-03-0-05

mm

	P	A	B	T	X <sup>1)</sup>	Y	F <sub>1</sub>	F <sub>2</sub>	F <sub>3</sub>	F <sub>4</sub>	G <sup>2)</sup>
	ø7.5	ø7.5	ø7.5	ø7.5		ø3.3	M5	M5	M5	M5	ø4
x	21.5	12.7	30.2	21.5		40.5	0	40.5	40.5	0	33
y	25.9	15.5	15.5	5.1		9	0	-0.75	31.75	31	31.75

inch

	P	A	B	T	X <sup>1)</sup>	Y	F <sub>1</sub>	F <sub>2</sub>	F <sub>3</sub>	F <sub>4</sub>	G <sup>2)</sup>
	ø0.30	ø0.30	ø0.30	ø0.30		ø0.13	M5	M5	M5	M5	ø0.16
x	0.85	0.50	1.20	0.85		1.61	0	1.61	1.61	0	1.31
y	1.02	0.62	0.62	0.20		0.36	0	-0.03	1.26	1.23	1.26

1) Port X must not be drilled, not sealed at valve base.

2) Min. 4 mm (0.16 in) depth

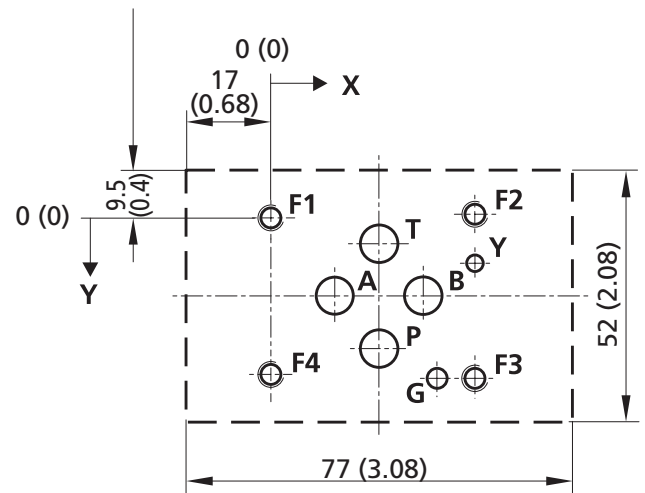

**SPARE PARTS AND ACCESSORIES**

Part designation	Quantity	Comments	Part number
O-rings for ports P, T, A, B	4	ID 9.25 mm (0.36 in) x Ø 1.8 mm (0.07 in): HNBR 90 Shore FPM 90 Shore	B97009-013 -42082-013
O-ring for port Y	1	ID 7.65 mm (0.30 in) Ø 1.8 mm (0.07 in): HNBR 90 Shore FPM 90 Shore	B97009-012 -42082-012
Sealing service kit	1 1	HNBR 90 Shore FPM 90 Shore  (not included in delivery)	B97215-H630F63 B97215-V630F63
Seals for venting port (D638 only)		HNBR FPM	B97018-060-003 B97018-060-002
Mounting screws servovalve	4	M 5 x 55, (DIN EN ISO 4762, Class 10.9, tightening torque 6.8 Nm [60 in-lb]) (not included in delivery)	A03665-050-055
Flushing plate for P, T, X, Y	1	 X T A P B Y (not included in delivery)	B46634-002
Shipping plate	1		B46035-001
Dust protection cover IP65 for field bus mounting connector – with external thread X3 – with internal thread X4	1 1	required for operation without mating connector (IP protection) (not included in delivery)	C55823-001 CA24141-001
Mating connector for 6+PE connector, IP65	1	DIN EN 175201-804 usable line with min. Ø 10 mm (0.39 in), max. Ø 12 mm (0.47 in) (not included in delivery)	B97007-061
Mating connector for 11+PE connector, IP65	1	DIN EN 175201-804 usable line with min. Ø 11 mm (0.43 in), max. Ø 13 mm (0.51 in) (not included in delivery)	B97067-111
6+PE-cable 3 m (120 in)	1	(not included in delivery)	C21033-003-001
11+PE-cable 3 m (120 in)	1	(not included in delivery)	C21031-003-001
Configuration/commissioning software	1	(not included in delivery)	B99104
USB comm. module	1	(not included in delivery)	C43094-001
Configuration/commissioning cable	1	(not included in delivery)	TD3999-137
Adapter M8 service connector	1	Additionally, configuration/comm. cable TD3999-137 required (not included in delivery)	CA40934-001
Power supply 10A	1	(not included in delivery)	D137-003-001
Power cable 2 m (80 in)	1	(not included in delivery)	B95924-002
Operating instructions Series D636/D638	1	(not included in delivery)	B95872-002





**ORDERING INFORMATION**

Model number (assigned at the factory)

Type designation

**D 638** . . . . . - . . . . .

1 2 3 4 5 6 7 8 9 10 11 12 13 14 15 16

**Specification status**

- Series specification
- Z Special specification

**Model designation**

**Factory identification**

**Variant**

**1 Valve version**

- R Servovalve with integrated electronics

**2 Rated flow**

	Q <sub>N</sub> [l/min] at Δp <sub>N</sub> = 35 bar (500 psi) per spool land	Δp <sub>N</sub> = 5 bar (71 psi)
02	5	2
04	10	4
08	20	8
16	40	16

**3 Pressure range in bar (psi)**

	max. operating pressure	
W	25	(363)
V	100	(1450)
U	160	(2320)
T	250	(3625)
K	350	(5075)

Calibrated pressure may differ from max. operating pressure

**4 Bushing/spool design**

- O 4-way: zero lap, linear curve
- A 4-way: 1.5 to 3% positive lap, linear curve
- D 4-way: 10% positive lap, linear curve
- B 3-way: P ↗ A, A ↘ T
- Z 2x2-way: P ↗ A, B ↘ T, only with Y-port
- X Special spool on request

- 1) This doesn't equal the hydraulic centered for bushing/spool design O, A
- 2) Only in combination with field bus connector "C, D, E" (change-over to analog signals "M, X, E" possible)
- 3) Only in combination with valve connector "E" and "C1" valve function
- 4) Only in combination with "B1" valve function
- 5) Valve parameterisation with commissioning software "MOOG VALVE CONFIGURATOR" using M8 service connector
- 6) Only in combination with field bus connector "C"
- 7) Only in combination with field bus connector "D, E, O"

Options may increase price.  
All combinations may not be available.

Preferred configurations are highlighted.

**16 Valve function**

- B1 p-function
- C1 pQ-function

**15 Service connector X10**

- O1 without<sup>6)</sup>
- K1 with<sup>7)</sup>

**14 field bus connector X3, X4**

- C CAN
- D Profibus DP<sup>5)</sup>
- E EtherCAT<sup>5)</sup>
- O without<sup>5)</sup>

**13 Enable function**

- B Linear motor without enable signal idle

**12 Valve function**

- M Pressure control<sup>4)</sup>
- N Pressure and flow control with pressure limitation (pQ)<sup>3)</sup>
- B Pressure control in the bypass

**11 Supply voltage**

- 2 24 V DC (18...32 V DC)

**10 Signals for flow Q and pressure p**

	Command Q	Command p
M	±10 V DC	0...10 V
X	±10 mA	0...10 mA
E	4...20 mA	4...20 mA
9	field bus digital <sup>2)</sup>	

Actual output valve  
Spool position/pressure 4...20 mA

**9 Valve connector X1**

- S 6+PE EN 175201 part 804
- E 11+PE EN 175201 part 804

**8 Seal material**

- H HNBR
- V FPM
- others on request

**7 Y-port**

- 0 Closed with plug p<sub>Tmax</sub> = 50 bar (715 psi)
- 3 Open, with filter insert p<sub>T</sub> > 50 bar (715 psi)

**6 Spool position without electric supply**

- M Mid position<sup>1)</sup>
- F P ↗ B, A ↘ T connected (10% open)
- D P ↗ A, B ↘ T connected (10% open)
- others on request

**5 Linear motor**      **Series**

1   Standard	D638
--------------	------

As the recognized leader in drive technology, Moog meets the high expectations of their customers by providing a comprehensive product service. Moog's experts provide specialist customer support to assist in selecting suitable products; they offer long term reliable operational customer support for selecting suitable products; these measures ensure long term reliable operation.

Our engineers can help in optimizing machine performance and reducing down times when it comes to commissioning of new machines, overhauling of older machines or general maintenance. Thus, smooth operation of our products is ensured.

**Moog Authentic Repair Service™** guarantees high quality repairs performed by highly qualified technicians using original spare parts and applying the latest specifications. This ensures that the machines which we repair work as new.

**With offices in more than 25 countries, Moog is well placed to offer a convenient local service.**

Refer to [www.moog.com/industrial/worldwide](http://www.moog.com/industrial/worldwide) to find your nearest Moog office for planning, repair and customer service.

FOR ADDITIONAL INFORMATION, REFER TO  
<http://www.moog.com/industrial>

# MOOG.COM/INDUSTRIAL

For the location nearest you, contact  
[moog.com/industrial/globallocator](http://moog.com/industrial/globallocator).

Argentina	+54	(0) 11 4326 5916	<a href="mailto:info.argentina@moog.com">info.argentina@moog.com</a>
Australia	+61	(0) 3 9561 6044	<a href="mailto:info.australia@moog.com">info.australia@moog.com</a>
Austria	+43	(0) 664 144 6580	<a href="mailto:info.austria@moog.com">info.austria@moog.com</a>
Brazil	+55	(0) 11 5523 8011	<a href="mailto:info.brazil@moog.com">info.brazil@moog.com</a>
China	+86	(0) 21 2893 1600	<a href="mailto:info.china@moog.com">info.china@moog.com</a>
Finland	+358	(0) 9 2517 2730	<a href="mailto:info.finland@moog.com">info.finland@moog.com</a>
France	+33	(0) 1 4560 7000	<a href="mailto:info.france@moog.com">info.france@moog.com</a>
Germany	+49	(0) 7031 622 0	<a href="mailto:info.germany@moog.com">info.germany@moog.com</a>
Hong Kong	+852	2 635 3200	<a href="mailto:info.hongkong@moog.com">info.hongkong@moog.com</a>
India	+91	(0) 80 4120 8799	<a href="mailto:info.india@moog.com">info.india@moog.com</a>
Ireland	+353	(0)21 451 9000	<a href="mailto:info.ireland@moog.com">info.ireland@moog.com</a>
Italy	+39	0 332 42111	<a href="mailto:info.italy@moog.com">info.italy@moog.com</a>
Japan	+81	(0) 46 355 3615	<a href="mailto:info.japan@moog.com">info.japan@moog.com</a>
Korea	+82	(0) 31 764 6711	<a href="mailto:info.korea@moog.com">info.korea@moog.com</a>
Luxembourg	+352	40 46 401	<a href="mailto:info.luxembourg@moog.com">info.luxembourg@moog.com</a>
Netherlands	+31	(0) 252 462 000	<a href="mailto:info.netherlands@moog.com">info.netherlands@moog.com</a>
Norway	+47	224 32927	<a href="mailto:info.norway@moog.com">info.norway@moog.com</a>
Russia	+7	(8) 31 713 1811	<a href="mailto:info.russia@moog.com">info.russia@moog.com</a>
Singapore	+65	677 36238	<a href="mailto:info.singapore@moog.com">info.singapore@moog.com</a>
South Africa	+27	(0) 12 653 6763	<a href="mailto:info.southafrica@moog.com">info.southafrica@moog.com</a>
Spain	+34	902 133 240	<a href="mailto:info.spain@moog.com">info.spain@moog.com</a>
Sweden	+46	(0) 31 680 060	<a href="mailto:info.sweden@moog.com">info.sweden@moog.com</a>
Switzerland	+41	(0) 71 394 5010	<a href="mailto:info.switzerland@moog.com">info.switzerland@moog.com</a>
United Kingdom	+44	(0) 168 429 6600	<a href="mailto:info.unitedkingdom@moog.com">info.unitedkingdom@moog.com</a>
USA	+1	(1) 716 652 2000	<a href="mailto:info.usa@moog.com">info.usa@moog.com</a>

©2007 Moog Inc.

Moog is a registered trademark of Moog, Inc. and its subsidiaries. All quoted trademarks are the property of Moog, Inc. and its subsidiaries. All rights reserved.

D636/D638\_en\_1/2007